

Instructions

Sinarback S 30|45
Mobile and Versatile

Sinar Photography AG
We do everything for the perfect picture

FCC Note:

This equipment has been tested and found to comply with the limits for a Class B digital device, pursuant to Part 15 of the FCC Rules. These limits are designed to provide reasonable protection against harmful interference in a residential installation. This equipment generates, uses, and can radiate radio frequency energy and, if not installed and used in accordance with the instructions, may cause harmful interference to radio communications. However, there is no guarantee that interference will not occur in a particular installation. If this equipment does cause harmful interference to radio or television reception, which can be determined by turning the equipment off and on, the user is encouraged to try to correct the interference by one or more of the following measures:

- Reorient or relocate the receiving antenna.
Increase the separation between the equipment and receiver.
- Connect the equipment into an outlet on a circuit different from that to which the receiver is connected.
- Consult the dealer or an experienced radio/TV technician for help.

FCC Caution:

To assure continued compliance, follow the attached installation instructions and use only shielded interface cables with ferrite core when connecting to computer or peripheral devices. Any changes or modifications not expressly approved by the party responsible for compliance could void the user's authority to operate this equipment.

Trade Name: **Sinar**Model No.: **Sinarback S 30I45**

Contains FCC ID: 2AJ8SS 30I45

This transmitter must not be co-located or operated in conjunction with any other antenna or transmitter. This equipment complies with

FCC radiation exposure limits set forth for an uncontrolled environment and meets the FCC radio frequency (RF) Exposure Guidelines. This equipment is tested for specific absorption ratio (SAR) and complies with FCC/IC radiation exposure limits set forth for an uncontrolled environment. This device complies with FCC/IC SAR limit of 1.6 W/kg. For body worn operation, this equipment has been tested and meets the FCC/IC RF exposure guidelines when used with the Sinar Photography AG accessories supplied or designated for this product that have no metallic component in the assembly. Use of other accessories may not ensure compliance with FCC/IC RF exposure guidelines.

For Japan:

This device is granted pursuant to the Japanese Radio Law (電波法) and the Japanese Telecommunications Business Law (電気通信事業法).

This device should not be modified (otherwise the granted designation number will become invalid).

T D 17-0005 202

R 202-LSF021

For Taiwan:

限用物質含有情況標示聲明書
Declaration of the Presence Condition of the Restricted Substances Marking

設備名稱：數碼相機背面，型號(型式)：S 30I45 Equipment name: Digital Camera Back, Type designation (Type): S 30I45						
單元 unit	限用物質及其化學符號 Restricted substances and their chemical symbols					
	鉛	汞	鎘	六价铬	多溴联苯	多溴二苯醚
	Lead (Pb)	Mercury (Hg)	Cadmium (Cd)	Hexavalent Chromium (Cr(VI))	Polybrominated biphenyls (PBB)	Polybrominated diphenyl ethers (PBDE)
电路模块 (Circuit Modules)	0	0	0	0	0	0
电缆及电缆组件 (Cables & Cable Assemblies)	0	0	0	0	0	0
金属部件 (Metal Parts)	-	0	0	0	0	0
塑料和聚合物部件 (Plastic and Polymeric parts)	0	0	0	0	0	0
光学和光学组件 (Optics and Optical Components)	0	0	0	0	0	0
电池 (Batteries)	0	0	0	0	0	0
備考1. "超出0.1 wt %" 及 "超出0.01 wt %" 係指限用物質之百分比含量超出百分比含量基準值。 Note 1: "Exceeding 0.1 wt %" and "exceeding 0.01 wt %" indicate that the percentage content of the restricted substance exceeds the reference percentage value of presence condition.						
備考2. "0" 係指該項限用物質之百分比含量未超出百分比含量基準值。 Note 2: "0" indicates that the percentage content of the restricted substance does not exceed the percentage of reference value of presence.						
備考3. "-" 係指該項限用物質為排除項目。 Note 3: The "-" indicates that the restricted substance corresponds to the exemption.						
茲切結保證所提供之商品限用物質含有情況標示內容係經執行測試作業或採適當之品質管理措施，並備置前述相關文件，確認正確無誤後提供貴局。並同意配合貴局執行後市場管理作業所需，依商品檢驗法第49條之規定，於限期28個工作天內提供相關證明文件以供審查。 I hereby ensure that "the presence conditions of the restricted substance" provided above have been proved by testing or appropriate quality control measures, and make sure the relevant documents provided are correct and ready. Also, I agree to cooperate with BSMI, as the Article 49 of the Commodity Inspection Act stipulates, to provide the relevant documents, if needed, for verification within 28 working days when BSMI carries out the market surveillance activities.						

Contents	Capturing Photos	18	Picture properties / contrast, sharpness, color saturation	27
Foreword.....	SINARBACK S 30I45 AND COPAL SHUTTERS	19	WHITE BALANCE	27
Table of Content.....	Setting up the hardware	19	DIRECT COLOR TEMPERATURE SETTING	28
Legal information.....	Capturing Photos	19	Manual setting by metering	28
Warning Messages	Wake Up	19	ISO sensitivity.....	29
Legal information	SINARBACK S 30I45 AND SINAR S-CS ADAPTERS	20	Storage of picture data / memory card management.....	29
Package Contents.....	Setting up the hardware	20	Capturing / Recording Mode	30
Designation of parts.....	The Menu Control	21	RECORDING MODE	30
Rear View	Menu control	21	For Photos.....	30
View from the Left	Controls / calling up menu control	21	Live View mode	30
Battery and Battery Charger	Exiting the menu.....	21	Live View photo / video mode / photography mode	30
Front and Top View	Menu function groups.....	21	Exposure simulation	30
Preparations.....	The Menu Control.....	22	Displays in Live View mode	30
Operational Modes	Navigating in the menu / setting the functions.....	22	Display settings	30
Data saving	Direct setting of the menu items without sub-menu	23	Histogram	30
Interfaces/Sockets	Further setting of the menu items with sub-menu	23	Clipping displays	30
Assembly and Commissioning	Quick access to menu functions	23	Notes on the histogram and the clipping indicators:	30
Charging the battery.....	Setting the function / customizing the buttons	24	Marking of clearly focused subjects (focus peaking)	31
For the use outside the USA.....	Calling up the selected menu functions.....	24	Grid	31
For use in the USA	Basic Camera Settings.....	25	Masking	31
Connection of the charger.....	PRESETS	25	Enlarging the Live View monitor image	31
CHARGING THE BATTERY.....	Camera default settings	25	Release button (31).....	32
Preparations.....	Menu language.....	25	Picture Series	32
Insertion	Date and Time.....	25	Interval Shooting	32
Removal.....	Time.....	25	Live View mode with Industrial Box.....	33
Charge level displays	Auto power Off	25	Exposure simulation.....	33
Changing memory cards.....	Signal tones	26	Display settings	33
CF cards (CompactFlash).....	Monitor	26	Histogram	33
Removal.....	Basic Image Settings.....	27	Clipping displays	33
SD / SDHC / SDXC cards	IMAGE DEFAULT SETTINGS.....	27	Marking of clearly focused subjects (focus peaking)	34
Insertion	Photo file format	27	Grid	34
System Charts	JPG SETTINGS	27	Masking	34
SINARBACK S 30I45 AND SINAR eSHUTTERS	Resolution	27	Enlarging the Live View monitor image	34
Setting up the hardware	Working color space	27	Distance setting	35

Manual setting - MF	35	Marking the picture files for copyright protection	43	Maximum enlargement in one step.....	50
AFs (single) = focus priority	35	Flash mode	44	Moving the detail.....	51
AFc (continuous) = shutter release priority	35	Connection via the the Lemo® Multisync socket (13)	44	Selection of one of the (contact sheet).....	51
Moving the autofocus metering field in Live View mode ..	35	Connection via the flash synchronization socket (7) $\frac{1}{2}$	44	Protecting pictures / clearing delete protection.....	52
EXPOSURE METERING	36	Video recordings.....	45	Deleting pictures.....	52
Exposure metering methods	36	Resolution / image frequency.....	45	Additional Functions	53
Spot metering	36	ISO sensitivity.....	45	ADDITIONAL FUNCTIONS.....	53
Center weighted metering.....	36	Color space	45	Transferring data to a computer	53
Multi-field metering	36	Constrast, focus, saturation.....	45	Transferring the data using card scanners	53
Exposure Control	36	Time code	45	Data structure on the memory card.....	53
Automatic Program Mode -P.....	36	Exposure metering methods.....	46	Installing firmware updates	53
Metering memory lock.....	37	Exposure modes	46	Data transmission / Remote control of Sinarback	54
Saving with the Joystick	37	Distance setting	46	WLAN settings	54
In AF mode.....	37	Starting / Ending the recording	46	Create personal password.....	54
In MF mode.....	37	Single pictures during video recordings.....	46	Change device name (SSID).....	54
Displays during saving of the exposure setting.....	37	Sound recording.....	47	Create connection to the Sinarback.....	54
Exposure compensation	37	Manual setting	47	Data transfer and remote control.....	54
Entering and canceling an exposure compensation.....	37	Deactivate sound recording	47	Miscellaneous	55
Manual setting of aperture and exposure time - M	38	Checking the sound recording	47	MISCELLANEOUS	55
Displays in Live View mode.....	38	Setting headphone volume	47	Sinar Back S 30 45 system accessories.....	55
Bracketing.....	38	Review Mode	48	Professional charger S.....	55
Displays in the monitor (in the picture data display)	38	REVIEW MODE.....	48	AC adapter S (power pack).....	55
Values above and below the metering range	39	Automatic review of last image.....	48	Remote cord S.....	55
Taking photographs with the self-timer	39	Review for unlimited time.....	48	HDMI cable.....	55
Procedure	39	Video playback.....	48	Audio adapter S	55
Displays	39	Setting the volume.....	49	Spare parts	55
Aborting the function	40	Displays in Review mode.....	49	Precautions And Care Instructions	56
ADDITIONAL FUNCTIONS.....	41	Review with histogram and clipping indicators.....	49	PRECAUTIONS AND CARE INSTRUCTIONS.....	56
User / application-specific profiles	41	The clipping displays.....	49	General Precautions.....	56
Renaming profiles.....	41	Marking of clearly focused subjects.....	49	Monitor	56
Folder management.....	42	Extended picture data.....	49	Sensor.....	56
Resetting picture numbers	42	Viewing other pictures / scrolling.....	50	Condensation	56
Changing file names	42	Enlarging the detail.....	50	Care instructions	56
Formatting the memory cards	42	Enlarging in steps.....	50	For the digital camera back.....	56

For the battery.....	56
For the charger	57
For memory cards.....	57
Cleaning the sensor	57
Storage	57
Technical Data.....	58
TECHNICAL DATA	58
The Displays.....	59
THE DISPLAYS	59
In the monitor	59
Capturing mode Live View photo	59
Standard view plus additional displays	60
Video recording mode	60
Photo review mode	61
Video review mode	62
The Menu Items	63
THE MENU OPTIONS.....	63
Sinar Service Addresses.....	64
Sinar product support.....	64
Sinar customer care.....	64

Legal information

Warning Messages

- Modern electronic components react sensitively to electrostatic discharge. As you can easily pick up charges of tens of thousands of volts by walking on synthetic carpets, for example, a discharge can occur when you touch your Sinarback S 30|45, particularly if it is lying on a conductive surface. If only the housing is touched, this discharge is harmless to the electronics. However, despite built-in safety circuits, outer contacts such as those in the bottom of the camera should not be touched if at all possible for safety reasons.
- For any cleaning of the contacts, please do not use an optical microfiber cloth (synthetic); use a cotton or linen cloth instead! Before touching the contacts, you can make sure you discharge any electrostatic charge by deliberately touching a heating or water pipe (conductive, earthed material). You can also avoid soiling and oxidization of the contacts by storing your Sinarback S 30|45 in a dry place with contacts covered.
- Use only the recommended accessories to prevent faults, short circuits or electric shock.
- Do not attempt to remove parts of the body (covers); qualified repairs can be carried out only at authorized service centers.

Legal information

- Please ensure that you strictly observe copyright laws. The recording and publication of prerecorded media such as tapes, CDs, or other published or broadcast material may contravene copyright laws.
- This also applies to all of the software supplied.
- The SD, HDMI, CF and USB logos are trademarks.
- Other names, company and product names referred to in these instructions are trademarks or registered trademarks of the relevant companies.

The CE identification of our products documents compliance with the fundamental requirements of the respective valid EU directives.

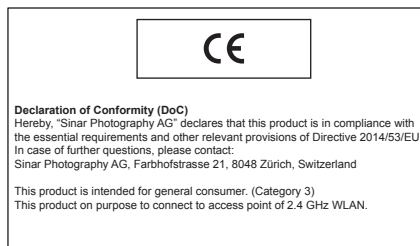

In the menu, under **Camera Information**, you will find the specific approvals for this Sinarback under the point **Regulatory Information**.



DISPOSAL OF ELECTRICAL AND ELECTRONIC EQUIPMENT

(Applies within the EU, and for other European countries with segregated waste collection systems.)

This device contains electrical and/or electronic components and should therefore not be disposed of in general household waste. Instead it should be disposed of at a recycling collection point provided by the local authority. This costs you nothing. If the device itself contains replaceable (rechargeable) batteries, these must be removed first and, if necessary, also be disposed of in line with the relevant regulations. Further information on this issue is available from your local administration, your local waste collection company, or in the store where you purchased this device.

Package Contents

Before using your Sinarback S 30|45 for the first time, please check that the accessories supplied are complete.

- Digital Device Sinarback S 30|45
- Quick Charger S with interchangeable mains plugs (16009)
- Rechargeable battery (16039)
- Lemo USB-3.0-cable for Sinarback S 30|45 (16040)
- WhiteShadingDiffusor 100 (S07043)
- Short Instructions Sinarback S 30|45

Meaning of the different note categories in this manual:

Note:

Additional information

Important:

Failure to observe the instructions may cause damage to the digital back, camera, accessories or the photos.

Caution:

Failure to observe the instructions may cause personal injury.

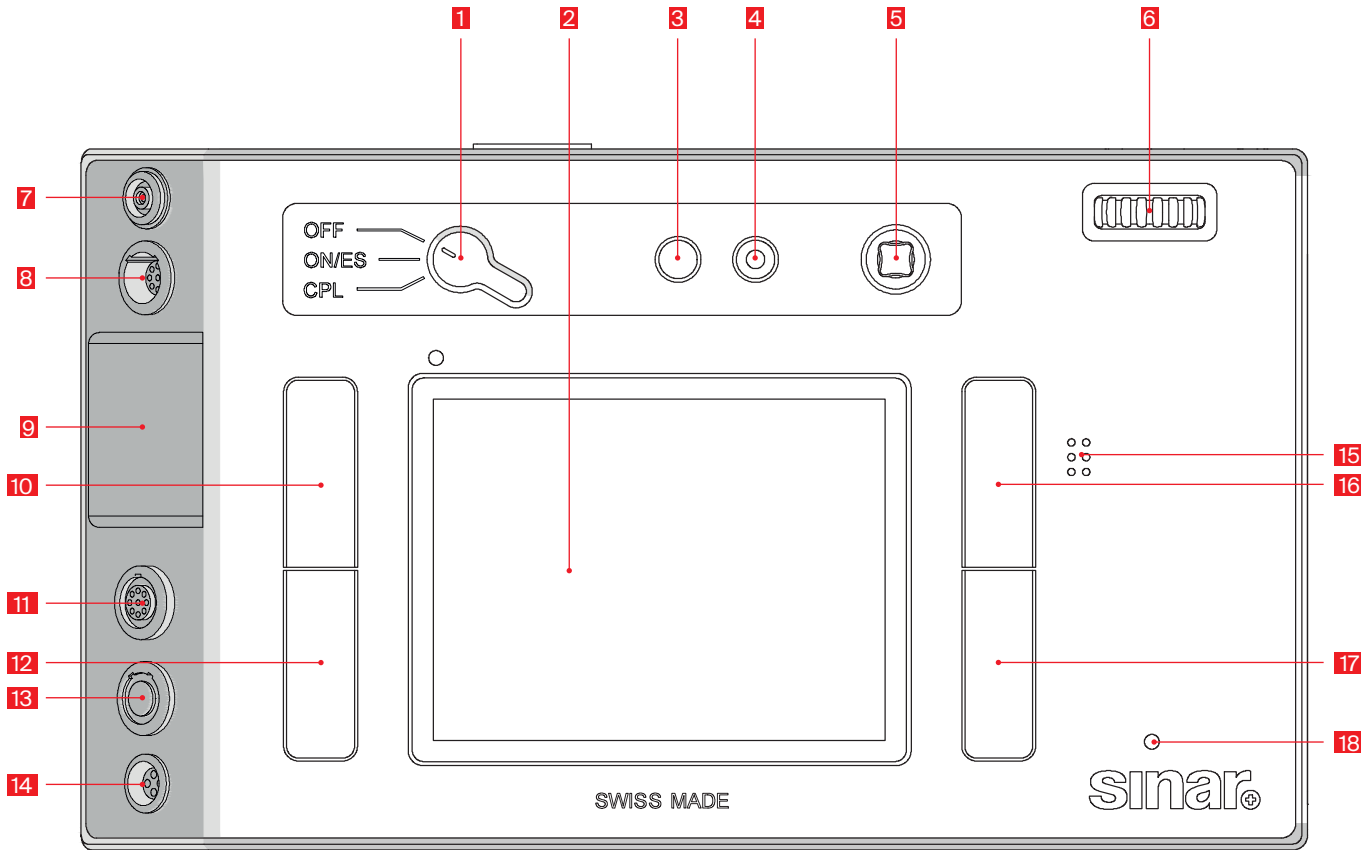

Rear View

- 1** Main switch with stop position
- 2** Monitor
- 3** Live view button
- 4** Video record button
- 5** Joystick
- 6** Setting thumbwheel with key function
- 7** Flash synchronization socket
- 8** Lemo® audio socket
- 9** HDMI socket
- 10** Menu control / Function button
- 11** Lemo® USB 3.0 socket
- 12** Menu control / Function button
- 13** Lemo® Remote control out / Multisync socket
- 14** Lemo® CPL / Trigger In socket
- 15** Beeper
- 16** Review / Menu control / Function button
- 17** Menu control / Function button
- 18** LED for recording data storage on card

View from the Left

- 21** Card slot door
- 22** CF Card ejection button
- 23** CF Card slot
- 24** SD Card slot
- 25** Type plate / WiFi antenna

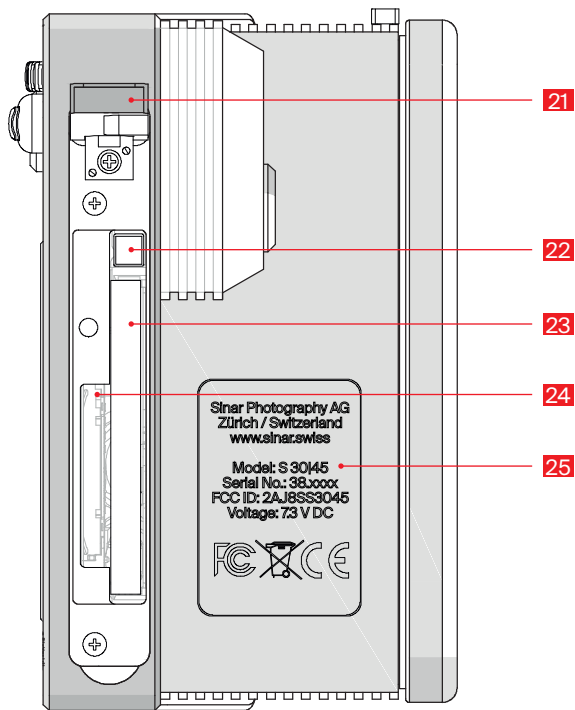

Designation of parts

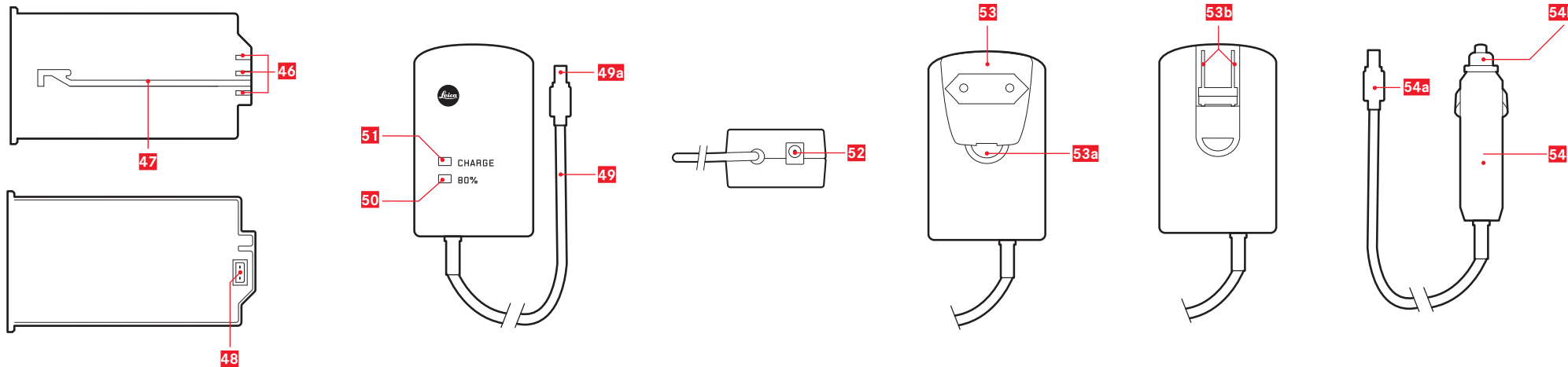

Battery and Battery Charger

Battery

- 46 Contacts
- 47 Guide slot
- 48 Socket for charger plug

Charger

- 49 Battery connecting cable plugged into battery with
- 49a 3-pin plug
- 50 Orange LED for charge indicator
- 51 Green LED for display of the charging process
- 52 2-pin socket for car charging cable
- 53 Interchangeable mains plug (Europe/GB/AUS) with
- 53a Release button
- 53b USA mains plug (interchangeable plug removed)
- 54 Car charging cable with
- 54a 2-pin plug for charger
- 54b Plug for cigarette lighter

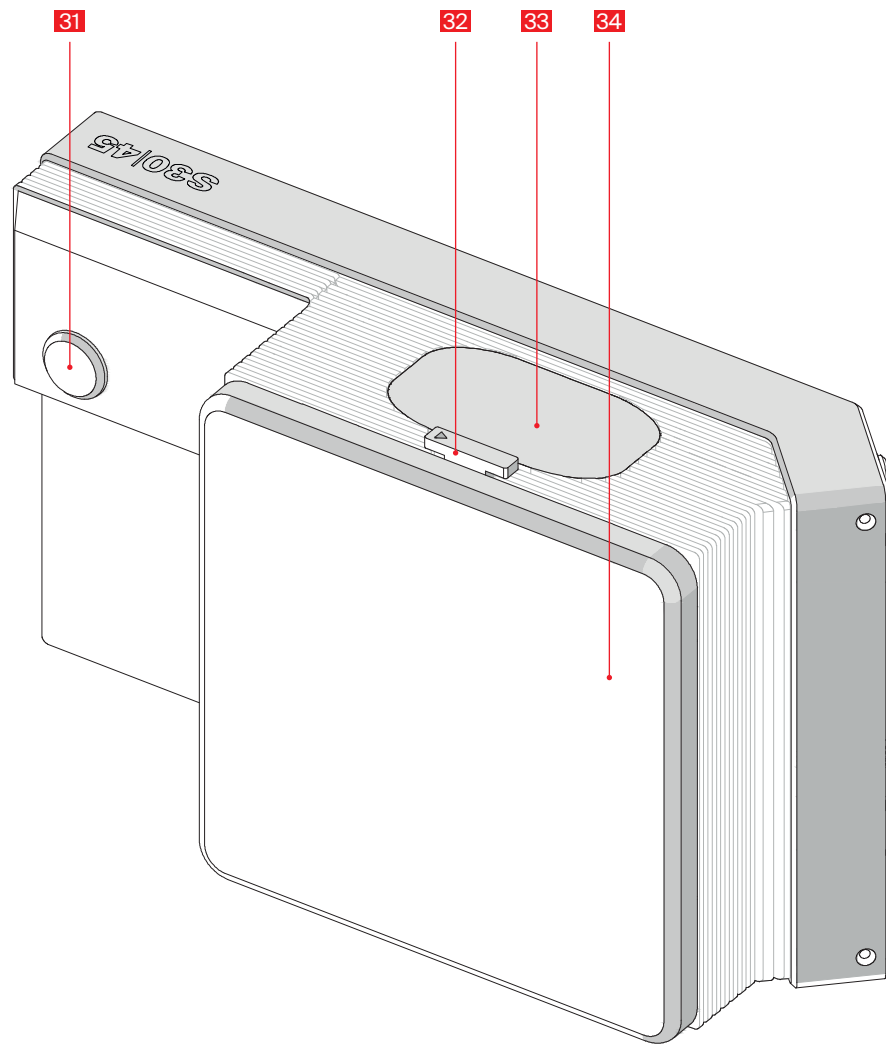

Front and Top View

- 31** Release button
- 32** Battery unlocking slider
- 33** Rechargeable battery
- 34** Sensor protection cover

Preparations

Operational Modes

Tethered Mode

In tethered mode the Sinarback S 30|45 is connected to the computer via USB. The Sinarback is remote-controlled using the suitable software Sinar CaptureFlow.

Note: You need the software Sinar CaptureFlow for the operation in tethered mode. It is available for download on Sinar's website www.sinar.swiss. **Batteries will not be charged over USB.**

Portable Mode (untethered)

In portable mode, the Sinarback S 30|45 is controlled by using the operational elements at the camera body and the Sinarback.

Data saving

Computer

When the Sinarback S 30|45 is remote-controlled from a computer, the images are saved in the selected directory on the computer. For further information, refer to the information in the ReadMe file of Sinar CaptureFlow.

Memory card

When the Sinarback S 30|45 is operated in portable mode, the images taken are saved on the memory card.

Interfaces/Sockets

LEMO® USB 3.0 socket (11)

Via the USB 3.0 socket the Sinarback can be connected to a computer and operated using Sinar CaptureFlow. The captured images are saved directly to the hard drive of the computer.

LEMO® CPL socket (14)

This Trigger In interface is used to synchronize the Sinarback with the shutter system. Connect the trigger cable to the Trigger In socket of your Sinarback S 30|45 and the shutter system.

Flash synchronization socket 4 (7)

When the flash synchronization socket at your shutter system is in operation, for example when the trigger cable is used, connect the flash device or studio flash unit to the flash synchronization socket of the Sinarback S 30|45.

Audio In/Out socket (8)

Use the Audio Adapter S (order No. 16 042) in order to simultaneously connect headphones or a microphone (both with 3.5 mm jack). The electric Remote Cord S (order No. 16 029) is highly recommended where maximum jitter-free photography is demanded.

HDMI socket (9)

Allows exceptionally fast transfer of picture data to display equipment with corresponding HDMI sockets.

Lemo® Remote control out / Multisync socket (13)

Allows for the connection of a Leica shutter release cable (item no. S16029).

WLAN

You can either control the Sinarback remotely using a smartphone/tablet or you can use the smartphone/tablet as an external storage medium. In order to do this, the Sinarback app must first be installed on your smartphone/tablet. This app is available in the Apple App Store™ for iOS™ devices.

Assembly and Commissioning

To attach the Sinarback S 30|45 to your camera, an adapter plate is required. The adapter plate depends on the camera type. In the following, the use of a fixed adapter is described.

Note: The information about your camera type has been taken with your order, and the necessary adapter kit is included in your delivery. If you are using another adapter than the one described in the following, a separate documentation describing the assembling of the adapter is included in your delivery.

The adapter plate is attached to the Sinarback by means of three recessed screws.

1. Remove the protective cover from the Sinarback S 30|45.
2. Put the Sinarback on an even surface, the sensor facing up.
3. Place the adapter plate on the Sinarback.
4. Insert the screws into the three holes. Tighten the screws alternately a little, do not fix one screw completely at a time. In this way you can avoid that the adapter plate to be fixed askew.
5. Attach the Sinarback to the camera. Make sure that it is mounted safely.

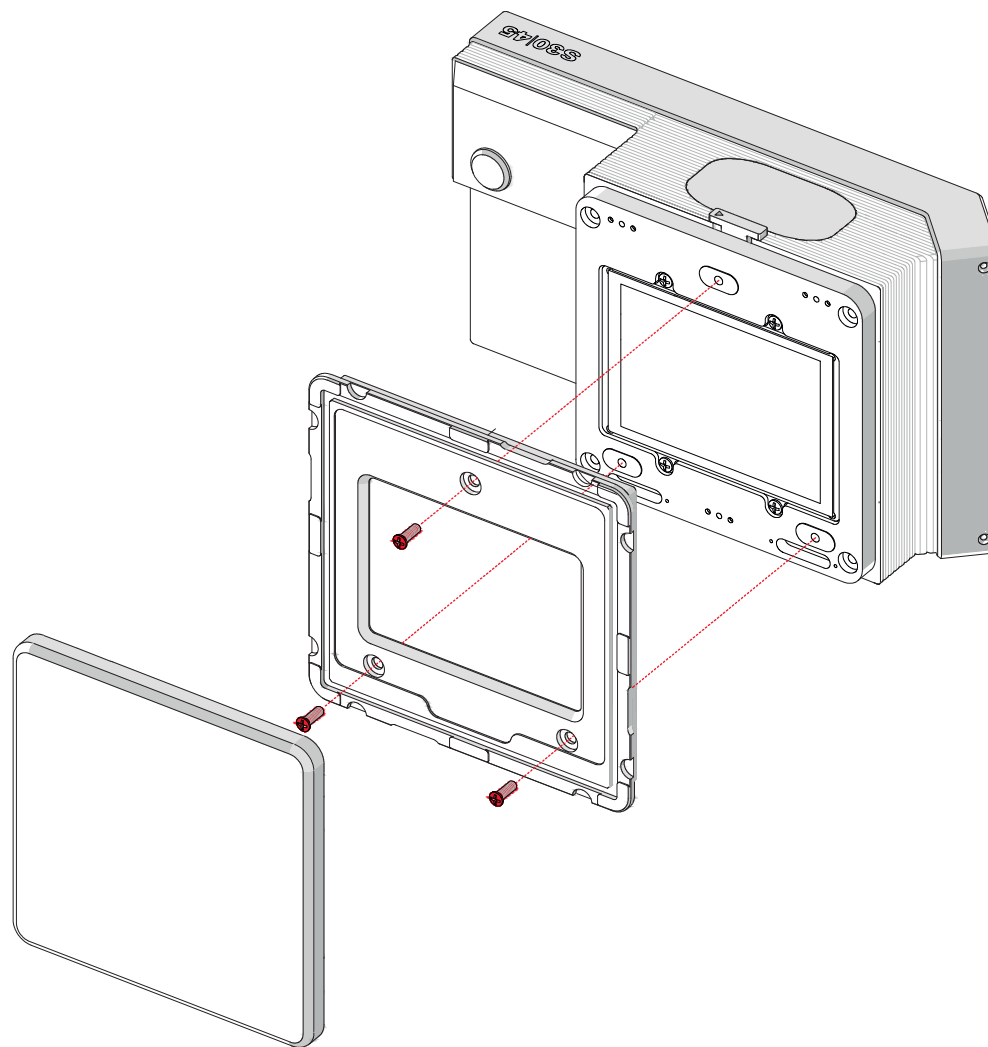

Preparations

Charging the battery

The Sinarback S 30|45 is powered by a lithium ion battery.

Important:

Please use only the Leica battery S BP-PRO1 (Order No. 16 039).

Caution:

- Only the battery type specified and described in this manual, or battery types specified and described by Sinar Photography AG, may be used in this digital back.
- These batteries may only be used in the units for which they are designed and may only be charged exactly as described below.
- Using this battery contrary to the instructions and using non-specified battery types can result in an explosion under certain circumstances!
- The batteries must not be exposed to sunlight or heat for prolonged periods, or to humidity or moisture. Likewise, the batteries must not be placed in a microwave oven or a high pressure container as this results in a risk of re or explosion!
- Damp or wet batteries must not be charged or used in the camera under any circumstances!
- Always ensure that the battery contacts are clean and freely accessible. Whilst lithium ion batteries are proofed against short-circuit, they should still be protected against contact with metal objects such as paper clips or jewelry. A short-circuited battery can get very hot and cause severe burns.
- If a battery is dropped, check the casing and the contacts immediately for any damage. Using a damaged battery can damage the camera.
- In case of noise, discoloration, deformation, overheating or leaking fluid, the battery must be removed from the camera or charger immediately and replaced. Continued use of the battery results in a risk of overheating, which can cause re and/or explosion!

- In case of leaking fluid or a smell of burning, keep the battery away from sources of heat. Leaked fluid can catch fire!
- Only the charger specified and described in these instructions, or other chargers specified and described by Sinar Photography AG, may be used. The use of other chargers not approved by Sinar Photography AG can cause damage to the batteries and, in extreme cases, can cause serious or life-threatening injuries.
- The charger supplied should be used exclusively for charging this battery type. Do not attempt to use it for other purposes.
- Ensure that the power socket used is freely accessible.
- The car charging cable supplied must never be connected while the charger is connected to the mains.
- Battery and charger must not be opened. Repairs may only be carried out by authorized service centers.
- Keep batteries out of the reach of children. Batteries can cause suffocation if swallowed.

First Aid:

- If battery fluid comes into contact with the eyes, there is a risk of blinding! Rinse the eyes immediately with clear water. Do not rub the eyes!
- Obtain medical assistance immediately.
- If leaked fluid gets onto the skin or clothing, there is a risk of injury. Wash the areas concerned with clear water. Obtain medical assistance.

Notes:

- The battery must have a temperature of +10°C to +30°C to be charged (otherwise the charger will not turn on, or will turn off again).
- Lithium ion batteries can be charged at any time, regardless of their current charge level. If a battery is only partly discharged when charging starts, it is charged to full capacity faster.
- A new battery only reaches its full capacity after it has been fully charged and – by use in the digital back - discharged again 2 or 3 times. This discharge procedure should be repeated roughly every 25 cycles.
- Both battery and charger become warm during charging. This is normal and not a malfunction.
- If the two LEDs flash rapidly (faster than twice per second) after the start of charging, this indicates a charging error (e.g. maximum charging time exceeded, voltages or temperatures outside the permitted ranges, or short circuit). In this case, disconnect the charger from the mains and remove the battery. Ensure that the above temperature conditions are met and then restart the charging process.
- If the problem persists, please contact your dealer, the Sinar dealer in your country or Sinar Photography AG.
- Lithium ion batteries should only be stored partly charged, i.e. not when fully discharged or fully charged. For very long storage periods, you should charge the battery for approx. 15 minutes roughly twice a year to avoid a deep discharge.
- Rechargeable lithium ion batteries generate power through internal chemical reactions. These reactions are also influenced by the ambient temperature and humidity. To ensure a maximum service life of the battery, it should not be exposed to constant extremes of temperature (e.g. in a parked car in the summer or winter).
- Even when used under optimum conditions, every battery has a limited service life! After several hundred charging cycles, this becomes noticeable as the operating times become significantly shorter.
- Dispose of damaged batteries in accordance with the relevant regulations (see p. 6, 56) at an approved collection point for proper recycling.
- The replaceable battery provides power to a back-up battery which is permanently fitted in the Sinarback. This back-up battery retains the set time and date for up to 3 months. If this back-up battery becomes discharged it must be recharged by inserting a charged main battery. Once the replaceable battery has been inserted, the full capacity of the back-up battery is recovered after about 60 hours. This process does not require the Sinarback to be turned on. In this case, however, the time and date have to be set again.
- Remove the battery if you will not be using the camera for a long period of time. When doing so, turn the Sinarback off using the main switch first. Otherwise after several weeks the battery could undergo deep discharge, i.e. the voltage is sharply reduced, as the Sinarback still consumes a small amount of current (e.g. for saving your settings).

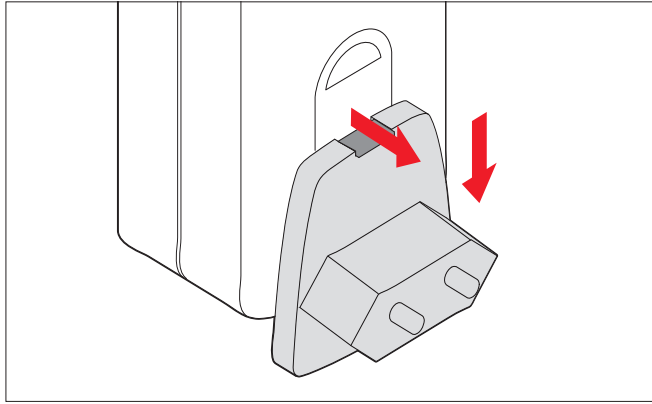
For the use outside the USA

1. Insert the appropriate plug for the local mains power supply into the charger. To do this, push up
 - a. the release button and at the same time push
 - b. the plug down out of its engaged position.
2. It can then be removed completely downwards.
3. Push the appropriate plug variant into the charger from below until it engages.

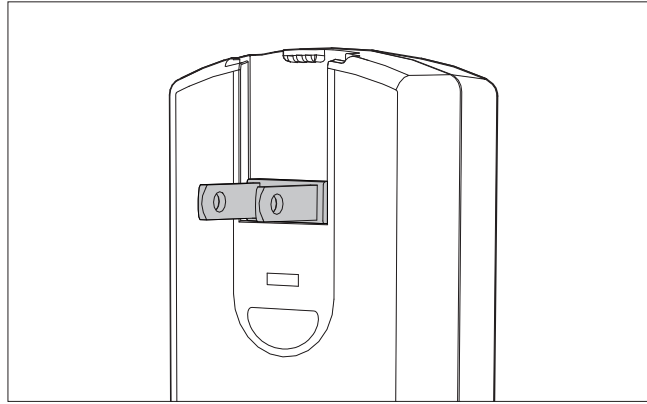
For use in the USA

1. Remove the mains plug fitted at the factory from the charger. To do this, push up
 - a. the release button and at the same time push
 - b. the plug up out of its engaged position.
2. The two pins of the USA plug that are normally horizontal when not in use can be folded out.

Notes:

The charger switches automatically to the prevailing mains voltage. In combination with the car charging cable supplied with the charger, it can be used in all vehicles with 12 V and 24 V power systems. In this case again, it switches over automatically.

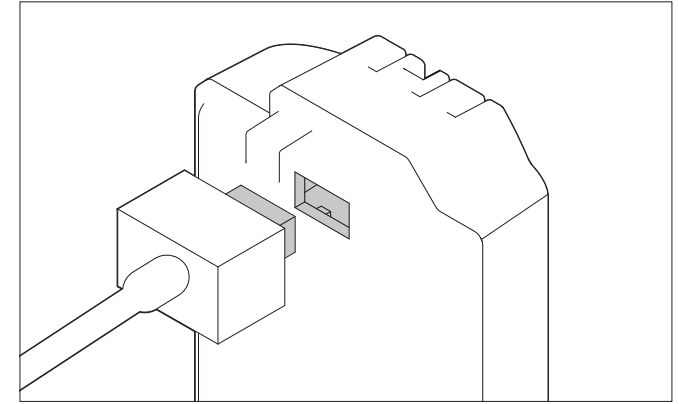
Connection of the charger

1. Connect up the charger, i.e. insert its cable plug into the socket of the battery and insert the mains plug into a plug socket.
 - The green LED marked CHARGE then starts to flash as confirmation that charging is in progress.
 - As soon as the battery has charged to at least 80% of its capacity, the orange LED marked 80% also lights up.
 - When the battery has been completely charged after approx. 3.5 hours, 100% capacity has been reached, the flashing green CHARGE LED changes to a steady light.

Notes:

- The 80% LED lights up after around 2 hours due to the charging characteristics. If the full capacity of the battery is not absolutely necessary, the camera can be ready for use again in a relatively short time.
- The steady light of the green CHARGE LED indicates that the charger has automatically switched to trickle charging.

2. The charger should then be disconnected from the mains power supply. There is, however, no risk of overcharging.

Preparations

CHARGING THE BATTERY

Preparations

Turn off the Sinarback, i.e. set the main switch to OFF.

Insertion

Push the battery with the contacts facing downward and with its guide groove facing the sensor of the Sinarback fully into the battery compartment. It engages automatically in this position.

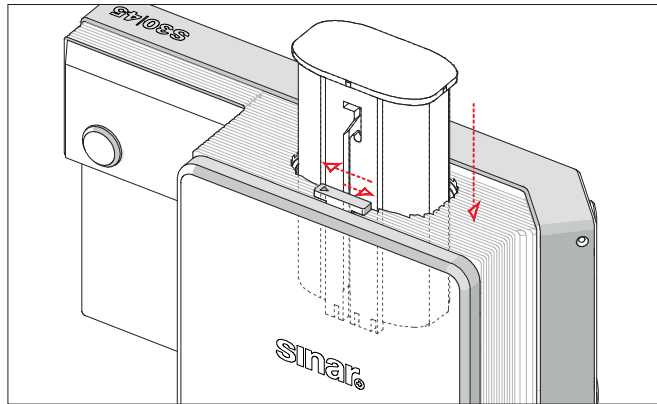

Removal

1. Move the release slide in the direction of the arrow until it stops
 - A spring in the battery compartment then pushes the battery approx. 1 cm out.
 - The locking mechanism has a detent so that the battery cannot accidentally fall out even if the Sinarback is held upside-down.
2. Push the battery approx. 1 mm back to disengage the detent, and
3. then pull it out of the compartment or, if the Sinarback is held upside-down, allow the battery to slide out into your hand.

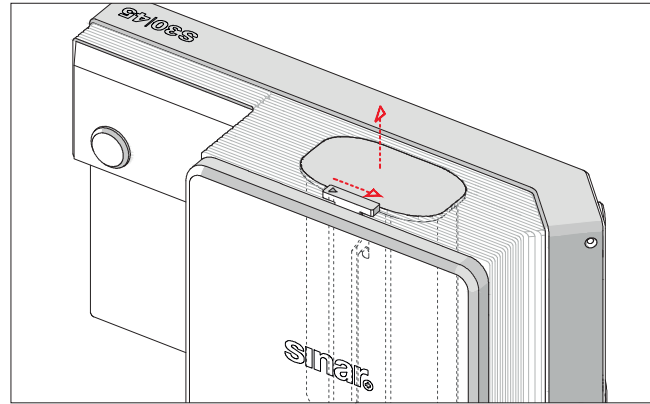

Charge level displays

Monitor	Charge status
	approx. \geq 85%
	approx. \geq 65%
	approx. \geq 40%
	approx. \geq 20%
	approx. \geq 5%
	approx. \leq 5%, replacement or recharging of the battery necessary

Changing memory cards

The Sinarback S 30|45 offers you the possibility of using 2 card types in parallel for storing of recorded data. It has two card slots, one for SD/SDHC/SDXC (Secure Digital) cards and one for CF (Compact Flash up to UDMA 7) cards.

Preparations

1. Turn off the Sinarback, i.e. set the main switch to **OFF**.

Note:

Do not turn off the Sinarback as long as the LED for data storage (18) is still lit.

2. Lift up the card cover door (21) on the side of the Sinarback.

Note:

Do not touch the contacts of the memory card.

CF cards (CompactFlash)

Insertion

Insert the card completely into the slot, with the contacts facing towards the Sinarback and the label towards the front of the Sinarback.

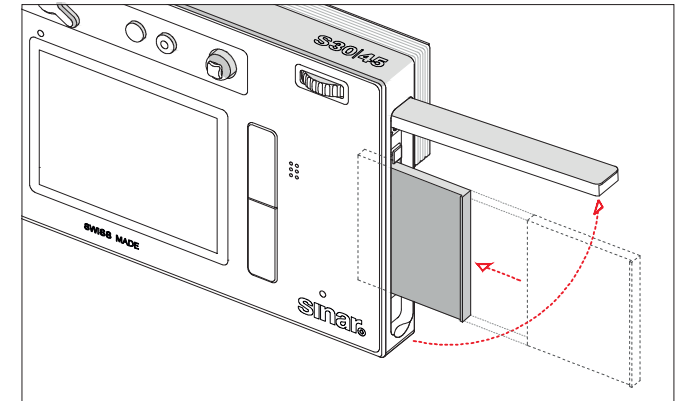

Note:

Ensure that the ejection button (22) is completely pushed in (see "Removal" on the following page).

Important:

Do not use force! The contacts in the card slot could otherwise be damaged!

Preparations

Removal

1. Lift up the card cover door (21) on the side of the Sinarback.
2. Push the ejection button inwards.
 - The button is then pushed out slightly.
3. Press the button inwards again.
 - The card is then pushed slightly out of the slot.
4. Pull out the card.

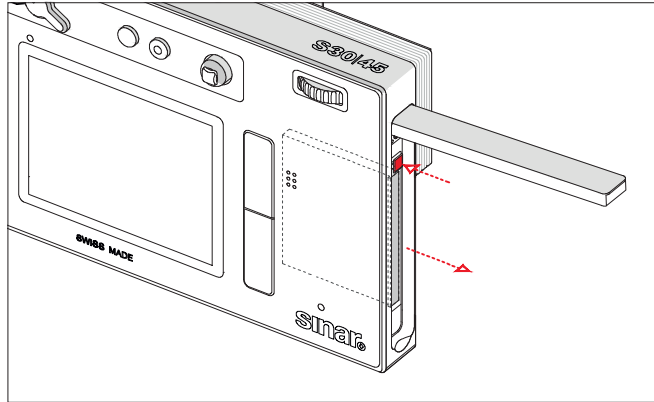

SD / SDHC / SDXC cards

Insertion

Insert the card completely into the slot, with the contacts facing towards the front and the label towards the rear of the Sinarback (the bevelled corner facing upwards), and press it against the spring pressure until it engages with a click.

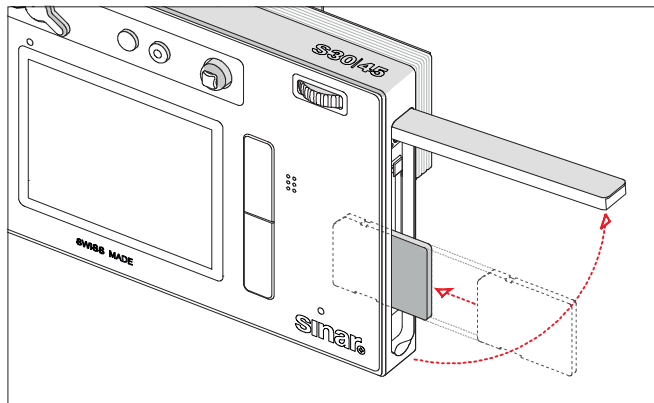

Important:

Ensure that no SD/SDHC/SDXC card is pushed into the CF card slot as it might not be possible to remove it again!

Removal

1. Lift up the card cover door (21) on the side of the Sinarback.
2. Press the card further into the slot.
 - The card is released and pushed slightly out of the slot.
3. Pull out the card.

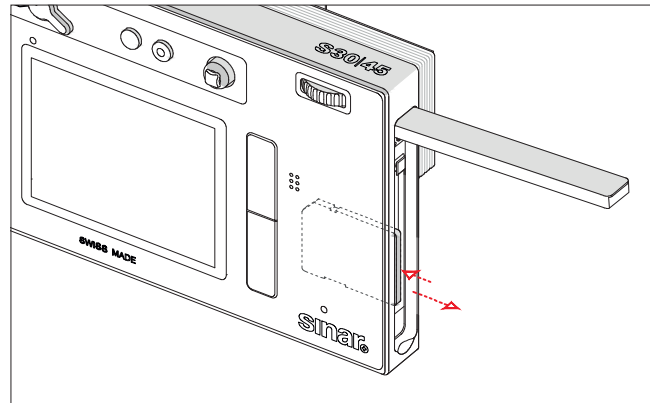

Close cover

Close the card slot door.

Displays



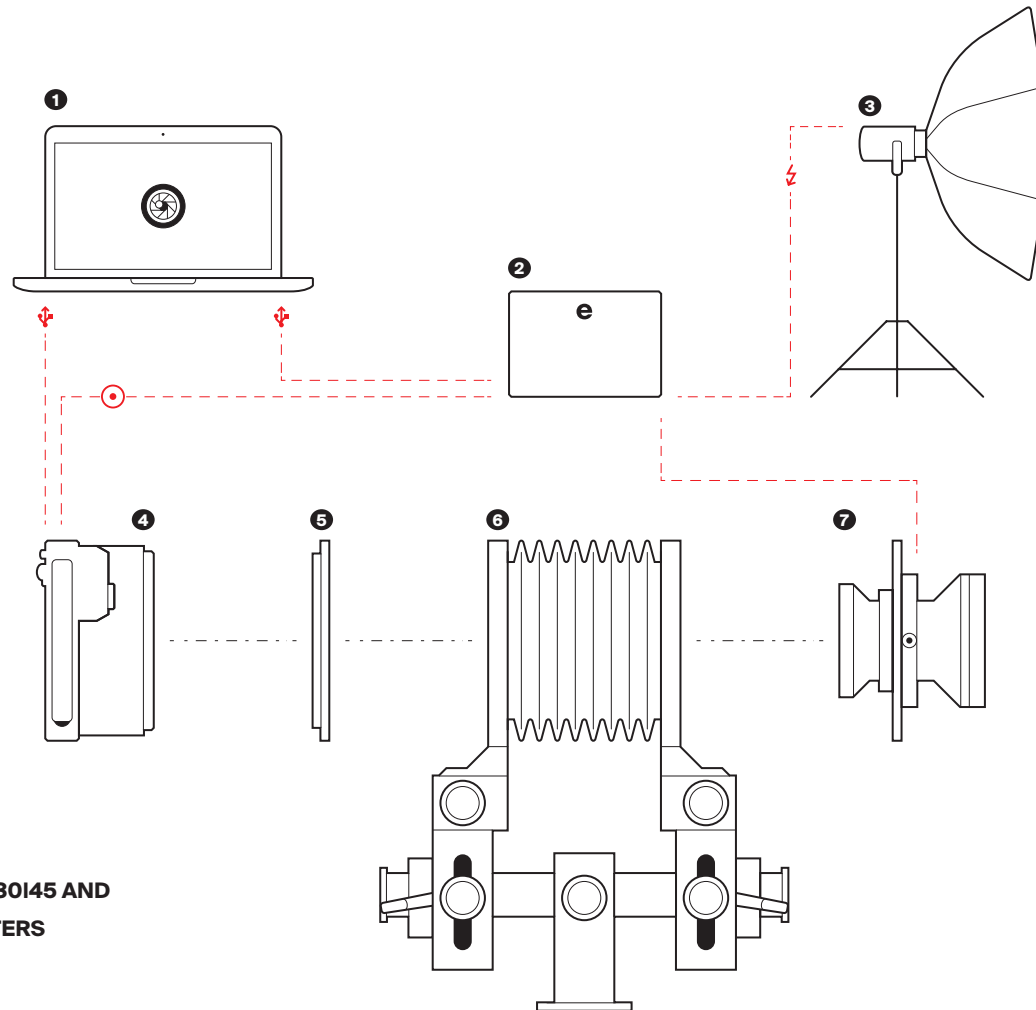

Memory card faults are indicated by different messages in the monitor.

Notes:

- If the memory cards cannot be inserted, check that they are aligned correctly.
- The range of available memory cards is too large to be fully tested for quality and compatibility by Sinar Photography AG. Although using other card types is not likely to damage the digital back or the card. Some “no name” cards do not comply with the memory card standards, and Sinar Photography AG is unable to provide any guarantee that they will function correctly.
- Do not remove either a memory card or the battery as long as the red LED (18) above the Sinar logo is flashing, indicating picture recording and/or data saving to the card(s). Otherwise the unsaved (or not completely saved) picture data may be lost.
- The Sinarback S 30|45 offers different variants for the storage of picture data. Further information on this topic can be found under “Storage of picture data / memory card management”.
- As electromagnetic fields, electrostatic charges, and defects in the camera or the card(s) can lead to damage or loss of the data on the memory card(s), we recommend that you also transfer the data to a computer and save it there.
- For the same reason we also recommend that the cards are always stored in an antistatic case.
- The proper function of the Sinarback cannot be guaranteed if WiFi cards are used.
- SD, SDHC, and SDXC memory cards have a write protection switch, which can be used to prevent unintentional storage and deletion of pictures. This switch takes the form of a slider on the non-bevelled side of the card; in the lower position, marked LOCK, the data is protected.
- Memory cards with a capacity of less than 1 GB cannot be used.



SINARBACK S 30|45 AND SINAR eSHUTTERS

-  – USB cable
-  – Flash connection
-  – WLAN connection
-  – Sinar eShutter/S30|45 Triggercable 50 (S07013)
- 1** – Sinar CaptureFlow
- 2** – Sinar eShutter Control (S04620)
- 3** – Flash
- 4** – Sinarback S 30|45 (S09010)
- 5** – S 30|45 Adapter (S09120, S09121 or third party)
- 6** – Sinar p3, Sinar lanTec or third party view camera
- 7** – Lens in Sinar eShutter

Setting up the hardware

1. Set the Main switch of the Sinarback S 30|45 to position: CPL
2. Plug in the Sinar eShutter/S 30|45 Triggercable 50 (S07013) into the Sinar eShutter Control (S04620) and connect it with the CPL/Trigger In socket (14) of the Sinarback S 30|45.
3. Connect the eShutter Control and the
4. Sinarback S 30|45 with two separate USB-cables with the same computer.

Note:

- Flash-Units have to be connected to the eShutter Control (S04620)
Please refer to the manual of the eShutter.

Capturing Photos

As the Sinar eShutter requires to be connected to a computer via USB, only tethered mode is supported.

The Sinar eShutter and the Sinarback S 30|45 are remote-controlled using the software Sinar CaptureFlow.

Note:



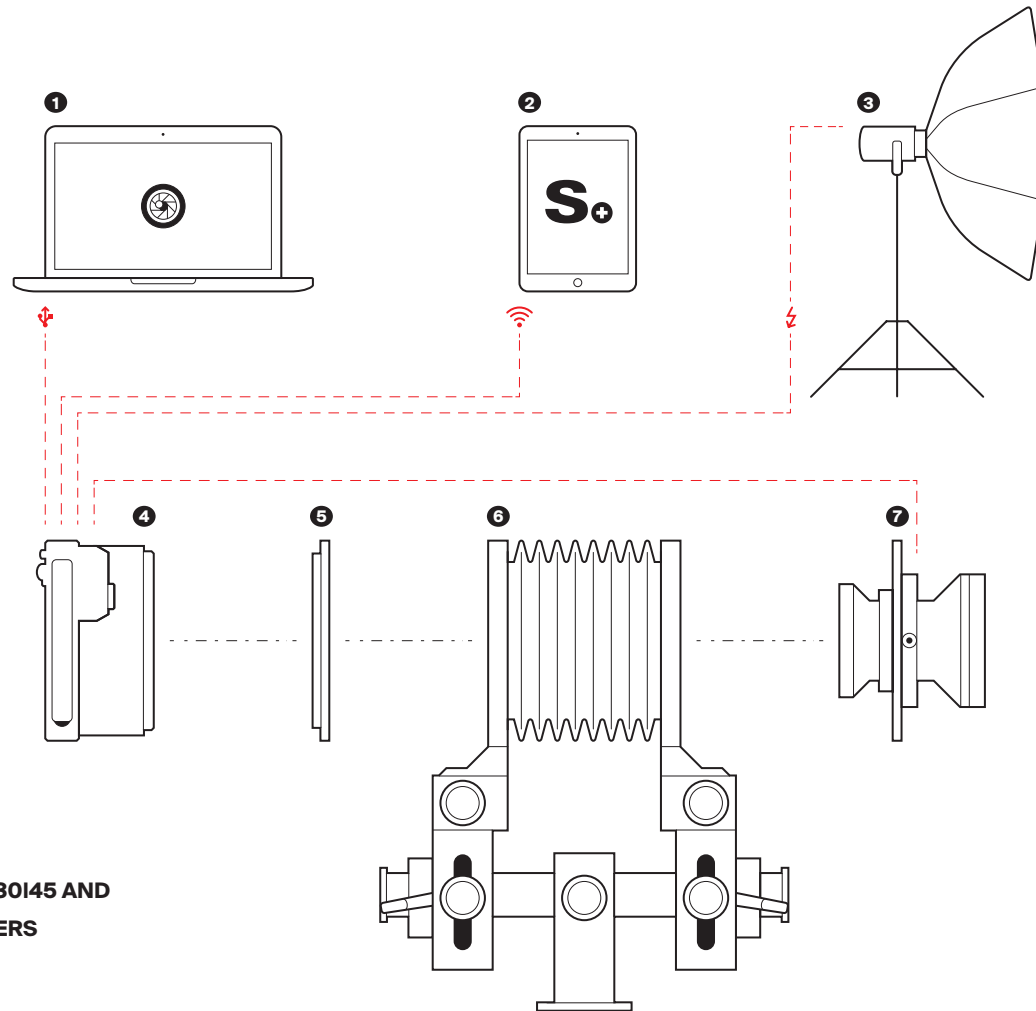

- The Sinarback S 30|45 is equipped with a release button (31). However, it has no functionality as a release button in this configuration.

Setting and using the functions

1. Activate Live View in Sinar CaptureFlow software for setting up camera and compose your picture.
2. Set exposure time and aperture in Sinar CaptureFlow software.
3. Use the controls in the software for taking images. In tethered mode the images are stored on your computer.



SINARBACK S 30|45 AND COPAL SHUTTERS

-  - USB cable
-  - Flash connection
-  - WLAN connection
-  - Trigger Cable S 30|45 (S07080)

- 1** - Sinar CaptureFlow
- 2** - Sinarback app (IOS device)
- 3** - Flash
- 4** - Sinarback S 30|45 (S09010)
- 5** - S 30|45 Adapter (S09120, S09121 or third party)
- 6** - Sinar p3, Sinar lanTec or third party view camera
- 7** - CPL-lenses, CEF-lenses or lenses in Copal shutter

Setting up the hardware

1. Set the Main switch of the Sinarback S 30|45 to position: CPL
2. Install the Trigger Cable S 30|45 (S07080) on your Copal shutter and connect with the CPL/Trigger In socket (14) of the Sinarback S 30|45.

Capturing Photos

A Sinarback S 30|45 in combination with a Copal shutter can be used in tethered and untethered operation mode.

Setting and using the functions

1. Tethered operation:

Sinarback S 30|45 is connected to a computer via USB and images are stored on the computer.

2. Untethered operation:

The mechanical Copal shutter is used for taking the picture and the Sinarback images are stored on CF-cards and SD-cards, respectively.

Setting and using the functions

1. Activate Live View for setting up the camera and composing your picture.
2. Open the Copal shutter.
Live View mode is based on the image captured by the sensor. To use it, the shutter must be open.
3. Close the Copal shutter and
4. Deactivate Live View when you are satisfied with your image composition.
5. Set exposure time and aperture on the Copal shutter.
6. Press the Release Button (31). Now the sensor is active for 5 seconds and you can ...
7. ... take images by releasing the Copal shutter.

Note:

- The Sinarback S 30|45 is equipped with a release button (31). However, it has no functionality as a release button in this configuration.

Wake Up

The Sinarback S 30|45 requires a wake-up signal before the Copal shutter is released and images can be taken.

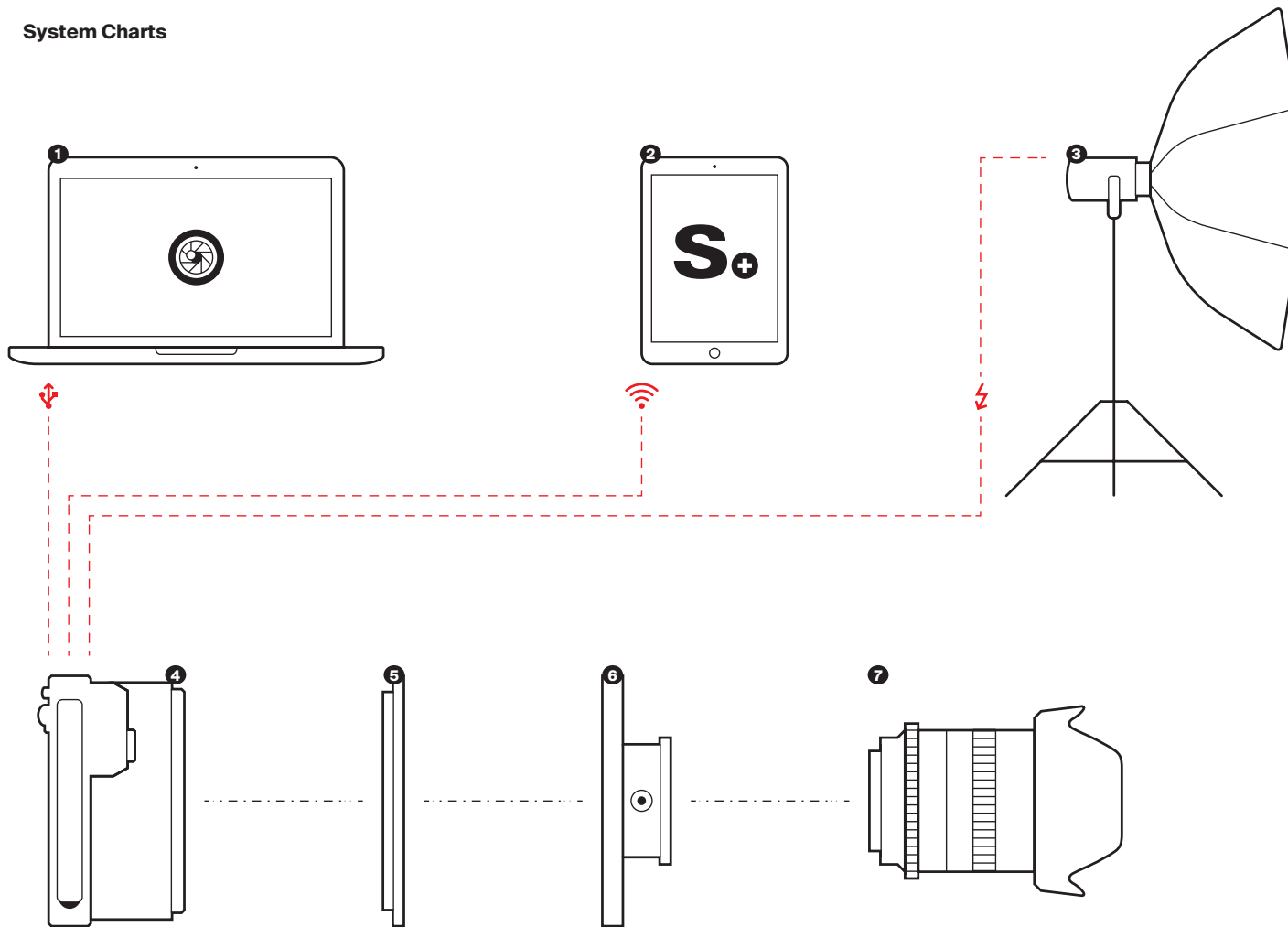

**SINARBACK S 30|45
AND SINAR S-CS ADAPTERS**

Setting up the hardware

1. Set the Main switch of the Sinarback S30|45 to position: ON / ES
2. Mount the Sinarback S30|45 onto the Sinar S-CS-Adapter (Industrial Box)

The Sinar Industrial Box is an adapter that allows to use the excellent Leica S-Lenses CS in combination with a Sinarback S 30|45.

Most of the functionality of the Leica S camera system is given.

- ↕ – USB cable
- ⚡ – Flash connection
- 📶 – WLAN connection
- ① – Sinar CaptureFlow
- ② – Sinarback app (IOS device)
- ③ – Flash
- ④ – Sinarback S 30|45 (S09010)
- ⑤ – S 30|45 -EL Adapter (S09121)
- ⑥ – Sinar S-CS-Adapter (S09150)
- ⑦ – Leica S (CS) lens

The Menu Control

Menu control

Most of the operating modes and settings of the Sinarback S 30|45 are operated by a menu control. Navigation and settings in the whole menu are very quick and simple as

- the menu items are divided into function groups, and
- also four user-defined menu items can be called up directly by holding the button depressed (quick access).

Controls / calling up menu control

Three of the four buttons to the left and right of the monitor are used for calling up menu control and for direct access to the function groups, namely the two buttons on the left and the lower right button.

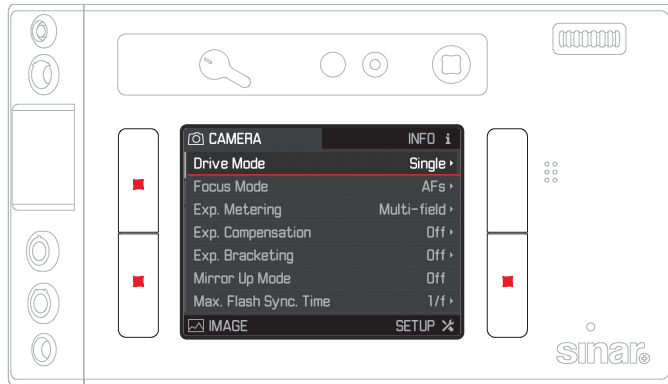

Note:

All four of these buttons are “soft keys”. Outside menu control, e.g. in Live View and video mode and during the review of pictures on the monitor, they have other functions that are indicated by corresponding displays.

All settings of the menu items can either be made with the rear thumb-wheel or the Joystick.

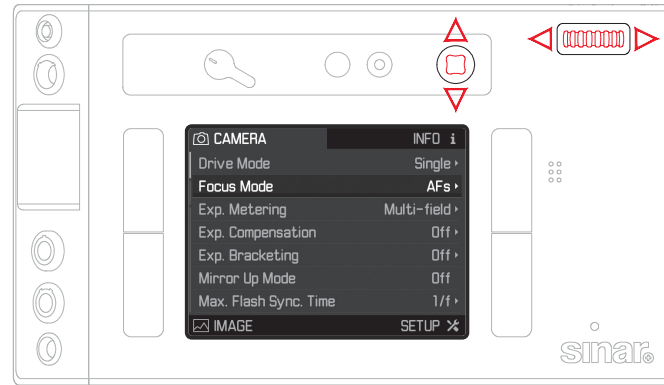

Exiting the menu

You can exit the menu in different ways:

- To switch to recording mode:
Press the shutter release button or the video record button, or press the Live View button
- To switch to the recorded data display:
Press the button top right – in this case marked **INFO** – briefly
- To switch to review mode:
Press the button top right while the recorded data are displayed – in this case marked **PLAY** – briefly again.

Menu function groups



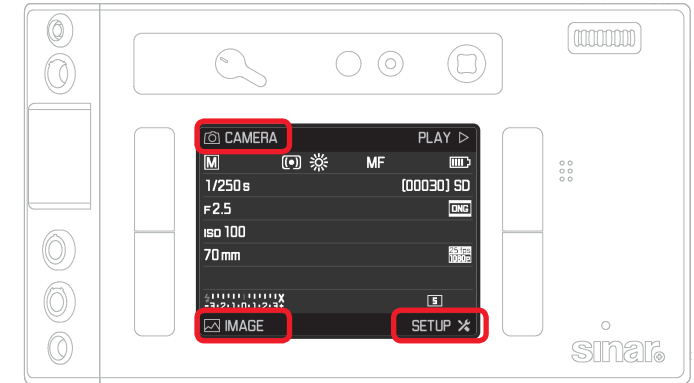

The menu of the Sinarback S 30|45 is divided into 3 function groups (see Annex “The menu items” as of page 63):

- **CAMERA**
- **IMAGE**
- **SETUP**



Navigating in the menu / setting the functions

1. Select the respective menu function groups by briefly (≤ 1 s) pressing the following buttons twice:

- Top left for the menu items of the Camera function group,
- Bottom left for the menu items of the Image function group, and
- Bottom right for the menu items of the Setup function group.
- If the monitor was previously inactive (dark), the Recorded data display appears when the button is pressed briefly the first time. The text boxes in the monitor image opposite the three buttons indicate the corresponding menu function groups.
- If these are displayed from review mode, the button functions valid in this situation are first displayed in an intermediate step:
 - Top left:  (Menu)
 - Bottom left:  (Delete)
 - Top right:  (Protect)
 - Bottom right:  (Recorded data display)

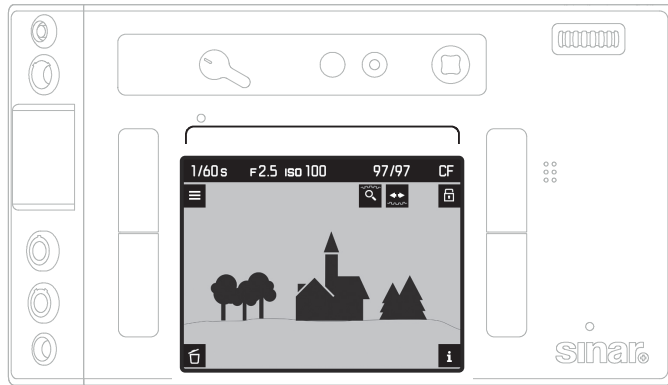

- As a guide, the menu screen displays the following:
 - in white letters, the selected menu function group
 - In the group **SETUP**, with a scrollbar on the left, which page of the list is currently selected
 - on each page in the individual lines, the menu items are displayed on the left, the corresponding settings are displayed on the right.
 - in white letters and red underline, the active menu function line (this applies to all menu levels). The currently set function variant or the currently set value is always displayed on the right side in the line.

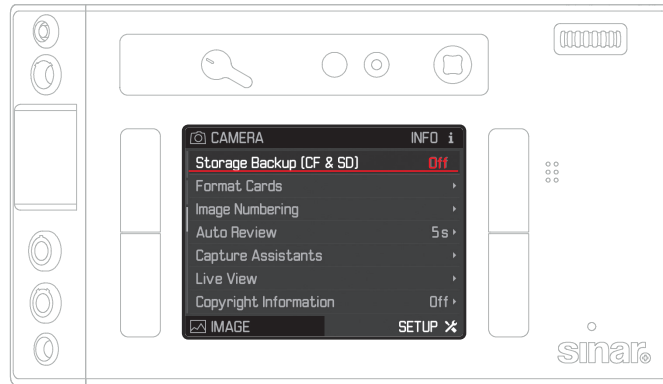

2. Select the individual menu items
- either by turning the thumbwheel to the right - scroll down / to the left - scroll up.
 - or by pressing the Joystick in the desired direction

The menu items of all three function groups form a common endless loop, i.e. they can all be reached in both directions.

When the menu is called up, the last menu item changed is always active.

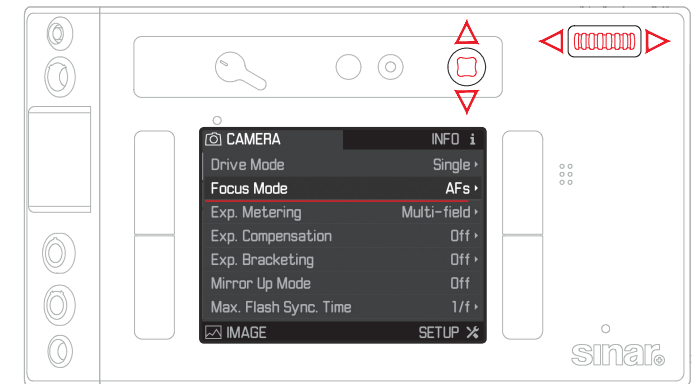

Direct setting of the menu items without sub-menu

3. (In the menu items without an arrow at the right-hand end of the line) Press either the thumbwheel or the Joystick forwards or to the right

- The set function variant changes. The setting is immediately active, i.e. it does not have to be confirmed.

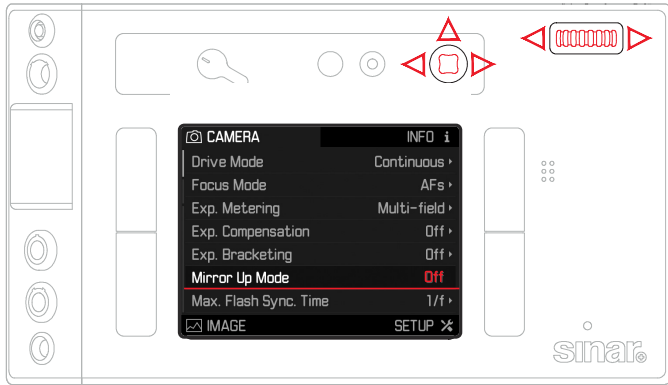

Further setting of the menu items with sub-menu

4. Press either the thumbwheel or the Joystick forwards or to the right to call up the list of the respective function variants

- The sub-menu in which the respective function variant or the values that can be set appears.

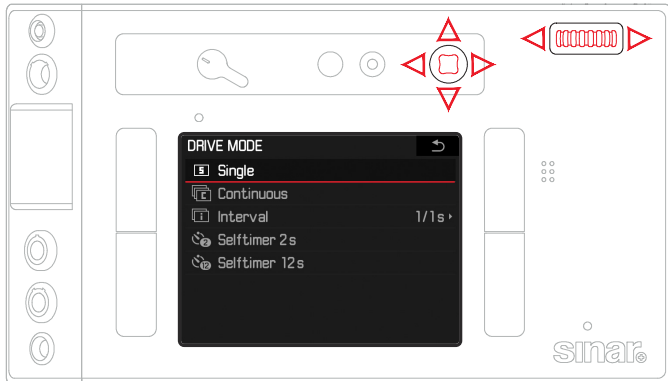

5. Turn either the thumbwheel to the right or left or press the Joystick in the desired direction (this differs, depending on whether a list or a scale is displayed) to select the desired function variant / the desired value.

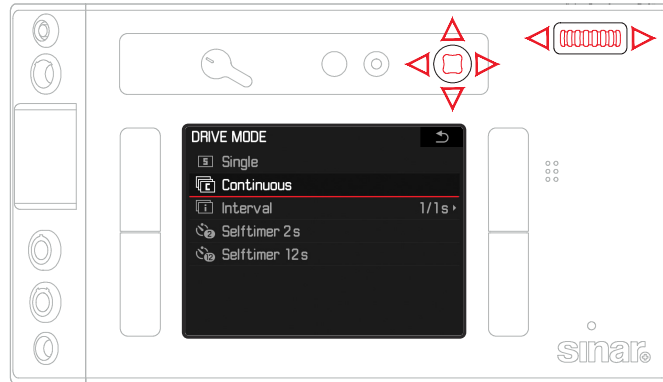

6. Press either the thumbwheel or the Joystick forwards to confirm the set function variant / the set value

- The display returns to the next higher menu level or switches to the next function variant for functions requiring further settings.

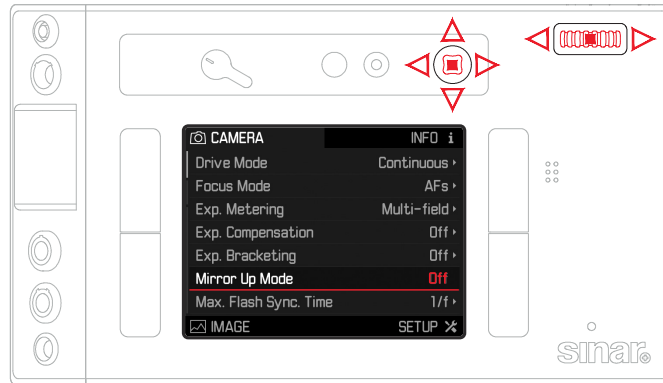

Note:

Briefly pressing the button marked  allows you to return to the menu at any time – without saving the changes made in the sub-menus up to that point.

Quick access to menu functions

For particularly fast operation you can use all four buttons to directly call up as many as 4 of the menu functions most important to you or the most frequently required menu functions.

First define which (menu) function you wish to call up with each of these buttons.

Note:

The buttons for the quick access are assigned as follows at the factory:

Button top left: **ISO**

Button bottom left: **Exp.metering**

Button top right: **Focus Mode**

Button bottom right: **Exp. compensation**

Setting the function / customizing the buttons

1. In the menu, under **SETUP**, select the item **Customize Controls**
 - A sub-menu appears with the three items **Short Cuts**, **AF/AE Lock Button** and **Rear Wheel Direction**.



2. In this sub-menu, select **Short Cuts**
 - A further sub-menu appears. If **Short Cut Mode** is not set to **Custom**, all the other items are inactive.

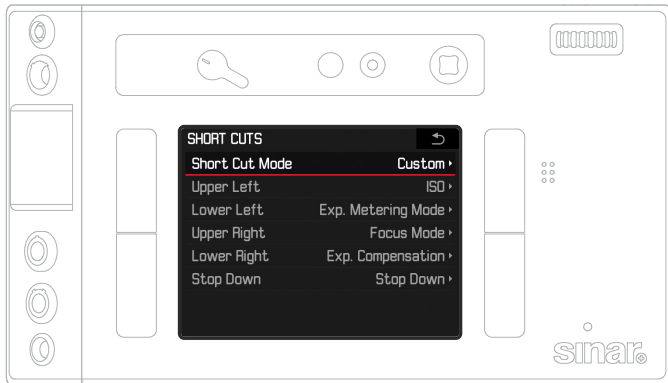

3. In this sub-menu, select **Short Cut Mode**
 - A further sub-menu appears.

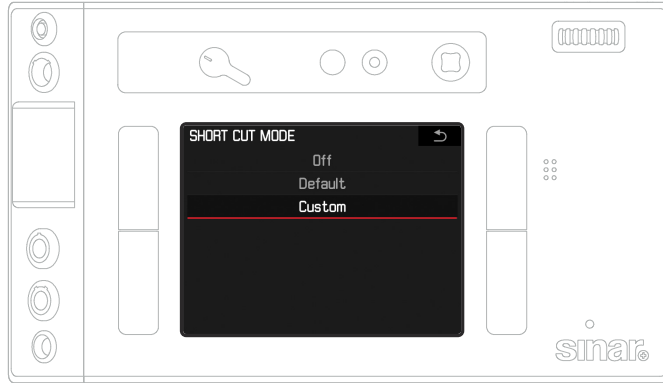

4. In this sub-menu, select **Custom**
 - (or **Default** if the factory setting of the button functions is to be used, or **Off** if the function is to be deactivated)
 - The menu displayed in step 2. appears again.

5. In the **Custom** sub-menu, select the desired button
 - A list with the available menu functions is displayed.

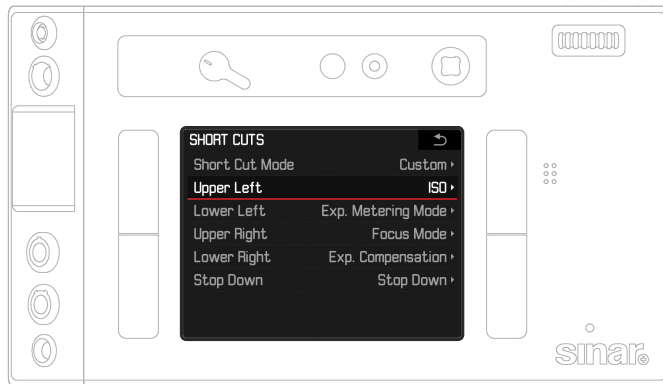

6. In the respective sub-menu, select the function you wish to call up or execute directly in future with the button selected in step 5, or **Off** if you do not wish to assign a quick access to this button

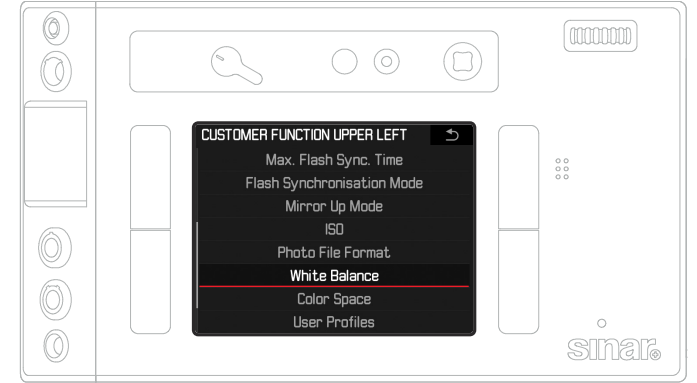

The other buttons are customized in the same way.
 • The menu displayed in step 2. then appears again.

Calling up the selected menu functions

You can then call up or execute the respective set (menu) functions directly at any time and make further settings there:
 Hold the buttons alongside the monitor pressed (longer than 1 sec.).

PRESETS

Camera default settings

Menu language

The language used in the default setting of the menu control is **English**, **German**, **French**, **Italian**, **Spanish**, **Russian**, **Japanese**, **Chinese Trad**, **Chinese Simp**, **Korean** and **Portuguese** can also be selected as alternative menu languages.

Setting the function

1. In the menu under **SETUP**, select the item **LANGUAGE** and
2. Select the desired language in the sub-menu.
 - Apart from a few exceptions (button names, short designations), all linguistic information changes.

Date and Time

There are 3 options available for the sequence of the date.

Setting the function

1. In the menu, under **SETUP** select the item **Date & Time** and
2. call up the sub-menu
3. Select **Date Setting** and call up the corresponding sub-menu
4. To change the representation **Day/Month/Year**, **Month/Day/Year** or **Year/Month/Day** press the Joystick up or down or turn the thumbwheel with the header line active.
5. Pressing the Joystick to the left or right takes you out of the marked header line to the three setting fields below, or back to the headerline.
6. In the respective marked setting field, make the settings by pressing the Joystick up or down or by turning the thumbwheel.
7. Confirm and save the settings by pressing the button marked OK in this case at the bottom right.

Time

Setting the function

In sub-menu item **Time-Setting** the settings are made for both the numerical groups and for the representation in essentially the same way as described in the previous section for the date.

Of the other three items in the **Date & Time** sub-menu, **Daylight Saving Time** is activated or deactivated by pressing the thumbwheel or the Joystick forward or to the right, while under **Time Zone** the desired location is selected from the list in the corresponding menu by turning the thumbwheel or pressing the Joystick up or down.

Notes:

- Even if no battery is inserted or the battery is discharged, the date and time settings are retained for roughly three months by an integrated back-up battery (see also “Charge level displays”). After that period, however, the date and time must be set again as described above.

Auto power Off

This function turns the camera off automatically after a preset time. This state corresponds to the main switch position **Off**.

Setting the function

1. In the menu, under **SETUP**, select the item **Auto Power Saving** and
2. set the desired time

Note:

Even if the camera is in standby mode, i.e. the displays have gone out or the activated **Auto Power Saving** function has turned it off, it can be reactivated at any time by pressing the shutter button.

Basic Camera Settings

Signal tones

With the Sinarback S 30|45 you can decide whether messages or autofocus mode should be confirmed by acoustic signals, or whether the camera operation should be more or less silent. Two volumes can be selected. The feedback is a beep tone that can be activated separately for autofocus mode to indicate the completed setting and as a signal for a message or warning.

Note:

In the factory setting the signal tones are deactivated.

Setting the functions

1. In the menu, under **SETUP**, select the item **Acoustic Signals** and
2. call up the sub-menu
It consists of the 3 items **Volume**, **AF Confirmation** and **Warnings**.
3. Under volume select **Low** or **High**
4. In the other sub-menus select whether or not you wish to activate the tones for the respective functions

If you select **On**

With AF confirmation a signal sounds as soon as the focus – whether automatic or manual – is set correctly. With **Warnings** a signal sounds together with all messages and warnings displayed in the monitor, and on expiry of the self-timer.

If you select **Off for Warnings**

Even if you select **Off**, an acoustic warning signal is nevertheless given in one situation:

- If the cover over the memory card slots is opened during data transfer.

Monitor

The monitor shows the complete image area, along with the selected data and information (see 'Displays on the Monitor', p. 59 ff). The brightness of the monitor is controlled automatically, depending on the ambient brightness. The sensor above the monitor is used for this function. Furthermore, its basic brightness can be adapted to the respective situation or to your personal wishes.

Setting the functions

1. In the menu, under **SETUP**, select the item **Display Brightness** and
2. select the desired setting in the sub-menu



IMAGE DEFAULT SETTINGS

Photo file format

Two file formats, DNG and JPG, are available for recording the picture data for photos. You can choose whether your picture data are to be saved

- in just one of these formats, or
- simultaneously in both formats (i.e. two files are always created per picture).

Setting the function

- In the menu, under **IMAGE**, select the item **Photo File Format** and
- select the desired format(s) or combination in the sub-menu

Notes:

- The standardized DNG (Digital Negative) format is used for storage of raw picture data.
- The remaining number of pictures shown in the monitor may not necessarily change after every picture. This depends on the subject; with JPG files very fine structures result in higher quantities of data, homogeneous surfaces in lower quantities. As a result the remaining memory capacity may be larger than previously calculated and displayed.

JPG SETTINGS

Resolution

Whereas the full resolution of 37.5 MP is always used in DNG format, two lower resolutions can also be used with the JPG format.

Setting the function

- In the menu, under **IMAGE**, select the item **JPG Resolution** and
- select **37.5MP**, **9.3MP** or **2.3MP** in the sub-menu

Working color space

The Sinarback S 30|45 allows one of three color spaces to be set, i.e. **sRGB**, **AdobeRGB** or **ECI RGB 2.0**.

Setting the function

- In the menu, under **IMAGE**, select the item **Photo Settings**
- then the menu item **Color Space**, and
- select the desired color range in the sub-menu

Picture properties / contrast, sharpness, color saturation

All three picture properties can be set – independently – to three different levels (with color saturation, four) using the menu control, so that you can set the optimum values for any situation, i.e. the prevailing lighting conditions. In the case of **Saturation**, **Monochrome** can also be selected as a fourth variant.

Setting the functions



- In the menu, under **IMAGE**, select the item **Photo Settings** and
- call up the sub-menu
- In this sub-menu select **JPG-Contrast**, or **Sharpness**, or **Saturation**, and
- select the desired level (**Low**, **Standard**, **High** or **Monochrome**) in the respective sub-menu

WHITE BALANCE

In digital photography, white balance ensures neutral rendition of color in any light. It is based on the camera being preset to reproduce a particular light color as white. In the Sinarback S 30|45 you can select between twelve different settings:

- AWB** **Auto** – for automatic control, which delivers neutral results in most situations,

Eight fixed presets for the most frequent light sources:

- Daylight** - e.g. for outdoor pictures in sunshine,
 - Cloudy** - e.g. for outdoor pictures with cloudy skies,
 - Shadow** - e.g. for outdoor pictures with the main subject in shadow,
 - Tungsten** - e.g. for indoor pictures with (predominantly) incandescent lamp light
 - HMI** - e.g. for indoor pictures with (predominantly) light from metal halide lamps (HMI)
 - Fluorescent Warm** - e.g. for (predominantly) light from fluorescent tubes with warm light color
 - Fluorescent Cool** - e.g. for (predominantly) light from fluorescent tubes with cooler light color
 - Flash** - e.g. for pictures with (predominantly) electronic flash lighting,
- Two **Greycard** settings for manual setting by metering (separately for the Live View  and the normal photo mode 
- K** **Color Temperature**¹ – for direct setting of a color temperature value (2000K - 13100 K).

¹ All color temperatures are specified in Kelvin.

Setting the function

Automatic and fixed settings

1. In the menu, under **IMAGE**, select the item **White Balance** and
2. select the desired function in the sub-menu

DIRECT COLOR TEMPERATURE SETTING

You can directly set values between 2000 and 13100K (from 2000 to 5000K in increments of 100, from 5000 to 8000K in increments of 200 and from 8000 to 13100K in increments of 300). This provides you with a broad scope, covering most of the color temperatures occurring in practice and within which you can adapt the color reproduction to the prevailing light color and/or your personal preferences.





1. In the menu, under **IMAGE**, select the item **White Balance**,
2. in the sub-menu select the variant **Color Temperature**, and
 - A further sub-menu appears with a list in which the value to be set is indicated by the red border.
3. select the desired value there.

Manual setting by metering

1. In the menu, under **IMAGE**, select the item **White Balance** and
2. select the desired greycard variant in the sub-menu

The further procedure differs, depending on the greycard variant.

If you have selected the normal photo mode :



- The message **Please take a picture for setting the white balance** appears in the monitor.
3. Take the picture, making sure that the image field contains a white or neutral gray (reference) surface.
 - The monitor shows
 - the image based on the automatic white balance setting,
 - cross hairs in the center of the image.
 - the button functions  and  valid in this situation
 4. Press the Joystick in the desired direction to move the cross hairs to the subject detail you want to use as the basis for the new white balance setting (e.g. the reference surface mentioned above)
 5. Press the button alongside the  display, or press the Joystick forward.
 - The color reproduction of the picture is adapted accordingly and the button function  valid in this situation is also displayed.
 6. You can now either
 - either accept this new white balance setting by pressing the button alongside the  display,
 - The message **White balance is set** appears in the monitor.
 - or make any number of further settings, as described under steps 3 to 6.
 - The message described under 2. appears each time in the monitor.

If you have selected the Live View photo mode :

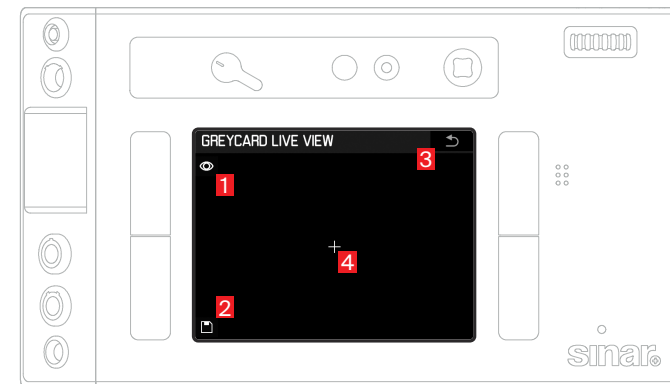
- The corresponding screen appears in the monitor.



- 1 Indication of button function: Perform white balance metering
- 2 Indication of button function: Save white balance metering (active only after metering)
- 3 Indication of button function: Back to normal photo mode (without saving any metered value)
- 4 Display of the metering field

1. Move the metering field to a white or neutral gray subject detail by pressing the Joystick in the desired direction
2. Carry out metering by pressing the  button at top left, or by pressing the Joystick forward
3. Save the metered value by pressing the  button at bottom left
 - The Sinarback switches back to the normal photo mode and the monitor image disappears.

Notes:

- The corresponding picture is always saved parallel to a saved white balance setting.
- A value set in this way remains saved and will be used for all following pictures until it is superseded by a new metered value or you use one of the other white balance settings.

ISO sensitivity

The ISO setting on the Sinarback S 30|45 allows a manual adjustment of the shutter speed/aperture values to the needs of the particular situation. As well as the fixed settings, the Sinarback S 30|45 also features the **ISO Auto** function, if the main-switch is set to ON/ES. The Sinarback automatically adjusts the sensitivity to the ambient brightness. When using the function, however, it is also possible to specify priorities, for example for compositional reasons. You can both limit the range of sensitivities used and set the shutter speed below which the sensitivity is automatically increased.

Notes:

A general rule of thumb in digital photography is that higher sensitivities result in increased noise. This has to be taken into consideration for the expectations on the picture quality. Please note that with picture series the frame rates decrease with higher sensitivities.

Setting the function

1. In the menu, under **IMAGE**, select the item **ISO** and
2. call up the sub-menu
It consists of the available ISO values and the point **ISO Auto**.

If you wish to set the sensitivity manually

3. select the desired value

If the sensitivity setting is to function automatically and without limitations

4. select **ISO Auto**.
The automatic setting uses all sensitivities and shutter speeds between 1/2 s and 1/500s

To restrict the automatic setting range

1. In the menu, under **SETUP**, select the item **Auto ISO Setup** and
2. select **Auto ISO Photo** in the sub-menu
3. Select **Maximum Auto ISO** and/or **Maximum Exposure Time**
 - When setting **Maximum Auto ISO**, a list with the available values appears, when setting **Maximum Exposure Time** a further sub-menu with several alternatives.
4. In the **Maximum AUTO ISO** menu list, select the highest sensitivity to be used, and hence the range within which the automatic setting is to operate, or in the **Maximum Exposure Time** sub-menu set either one of the three focal length-specific settings - **1/f**, **1/2f**, **1/4f** or the desired slowest shutter speed. With the **1/f** settings the camera switches to the higher sensitivity if the shutter speed would drop below the selected threshold due to a lack of brightness, e.g. with a 70 mm lens with shutter speeds lower than 1/60s (with **1/f** (f=focal length)), or 1/25s with 1/2f, or 1/250s with 1/4f *.

Note:

The factory setting of 1/2f results in the slowest shutter speeds according to the rule of thumb adapted for this format for blur-free pictures taken from the hand, e.g. 1/25s with a 70 mm lens. The corresponding shutter speeds with 1/2f and 1/4f in this example would be 1/60s and 1/250s.

Storage of picture data / memory card management

If two memory cards are used, with the Sinarback S 30|45 you have the possibility to choose

- whether the picture data should first be stored on one of the two cards until its capacity is reached, and then on the other card, or whether the data should
- always be stored simultaneously on both cards.

Setting the function

1. In the menu, under **SETUP**, select the item **Storage Backup (CF & SD)** and
2. there select **Off** or **On**

Note:

If **Off** is selected:

- The picture data are first stored on the SD/SDHC/SDXC card and then, once its capacity is reached, on the CF card. As soon as the Sinarback is connected to a computer, it stores the picture data only in the specified folder on the computer.

If **On** is selected:

- The picture data are stored simultaneously on both cards.

With both settings:

- If only one card is used (regardless of which), the picture data are stored there.

¹ The function is not available when using flash units.

RECORDING MODE

For Photos

Sinarback S 30|45 is designed for the work with a View Camera.

It supports the following shutter-systems:

1. Sinar eShutter
2. Copal Shutter
3. Sinar S-CS-Adapter

The configurations are explained in detail on the following pages

Live View mode

Live View mode permits continuous viewing of the subject on the monitor, i.e. both before and during capturing. Live View mode is switched on and off, and video mode is switched on (without starting recording) with the LV button (3). Pressing the button displays the functions in turn (in an endless loop).

Live View photo / video mode / photography mode

- When switched on, the functions of the adjacent buttons are displayed for 3 seconds in the four corners of the monitor picture.
- Video mode is always performed using the monitor picture.

Notes:







- Additional autofocus and exposure metering function variants can be used according to camera configuration during Live View mode, see the corresponding sections.
 - Live View mode is based on the image captured by the sensor. To use it, the shutter must be open.
 - Depending on camera configuration the shutter is opened automatically or has to be opened by hand.
 - Frequent use of the Live View mode results in increased power consumption.

Exposure simulation

In the factory setting, the Live View monitor picture shows a monitor picture with constant brightness, irrespective of the exposure settings. The “generally” constant brightness presupposes, however, that the subject brightness and the set exposure do not result in any excessively high or low brightness values, and that the internal exposure time is not longer than 1/30s.

Displays in Live View mode

With the standard setting, the Live View monitor image contains the following displays (see “The displays / In the monitor / Capturing mode Live View photo”):

- In the header some fundamental information
- In the corners of the picture, symbols for the functions of the buttons alongside the monitor:  = Play,  = Change of display,  = Magnify, and  = Menu
-  Spot autofocus meteringfield (+ autofocus metering crosshair)
-  Autofocus metering crosshair
- Exposure simulation
- Or Key lock 

Display settings

Repeatedly pressing the button bottom right calls up various additional displays/information in turn:

- Histogram and clipping indicators
- Marking of clearly focused subjects
- Grid lines and horizon
- Extended image data
- Back to the normal view

Histogram

The histogram depicts the brightness distribution in the image. The horizontal axis shows the brightness values from black (left) through gray to white (right). The vertical axis corresponds to the number of pixels at each brightness level. This form of representation – together with the impression of the image itself – provides an additional quick and easy assessment of the exposure setting.

Clipping displays

These displays indicate the picture areas without marking.

Setting the function

1. In the menu, under **SETUP**, select the item **Capture Assistants** and
2. select **Exposure Clipping** in the sub-menu
3. In the sub-menu select **Lower Limit** or **Upper Limit**, and
4. set the desired threshold values on the scale by turning the thumbwheel or by pressing the Joystick to the left or right
 - The scale shows the clipping areas relative to the overall exposure range.

The following then appears in the pictures:

- Excessively light areas are indicated in red, excessively dark areas in blue, flashing in each case. The clipping symbol ([]) also appears in the top right corner.

Notes on the histogram and the clipping indicators:

- Both are available also in Play mode.
- Both always refer to the currently displayed detail (see “Enlarging the Live View monitor image”).

Capturing / Recording Mode

Marking of clearly focused subjects (focus peaking)

In Live View mode, the Sinarback S 30|45 can mark subjects imaged with optimum focus in the monitor picture by highlighting their contours. This simplifies their recognition and hence in particular the manual setting of the focus. The three available colors permit adaptation to any background.

Setting the function

1. In the menu, under **SETUP**, select the item **Capture Assistants** and
2. select **Focus Peaking** in the sub-menu
3. Call up the sub-menu, and
4. select the desired color there
 - All subject details that are in focus at the set range are indicated by outlines in the selected color.

Further information on setting the focus can be found in the corresponding sections.

Note:

When using high ISO values and/or slow shutter speeds, the function may not work.

Important:

This function is based on the subject contrast, i.e. light/dark differences. Therefore, subject details that are not completely in focus but have a high contrast may also be marked.

Grid

The Sinarback S 30|45 offers you two variants of grid lines as an aid to picture composition.

Setting the function

1. In the menu, under **SETUP**, select the item **Capture Assistants**,
2. select **Grids** in the sub-menu, and
3. select **3x3** or **6x4** in the sub-menu
 - If the view with horizon and grid is selected, the selected grid is displayed in the monitor.

Masking

In addition to the standard aspect ratio (2:3) for photos, three further ratios are available when using the DNG format: 1:1, 16:9, 2:1. They open up further composition possibilities while taking the picture.

Setting the function

1. In the menu, under **SETUP**, select the item **Capture Assistants**,
2. select **Photo Masks** in the sub-menu, and
3. select the desired format there
 - The monitor picture is masked accordingly, with 1:1 left and right, with 16:9 and 2:1 top and bottom. While taking the photograph the mask is transparent, during review of corresponding photos in the camera it is not.

Note:

Irrespective of the aspect ratio selected, the whole 2:3 image field is always recorded, i.e. the masking of the monitor picture affects only the display in the camera. Although the photo is initially displayed with the selected aspect ratio in image processing programs, it is possible to delete the masking there so that the whole 2:3 image field is available again.

Enlarging the Live View monitor image

Select differently enlarged details:

Press the button bottom left repeatedly

- This gives in turn
 - Double the size
 - Four times the size
 - Back to normal size
- The buttons are not displayed with the enlarged view; a frame appears in the bottom left-hand corner that indicates the position of the detail in the picture.

To shift the detail:

Press the Joystick left, right, up, or down

Notes:

- The grid line display is not available with the enlarged view.
- After switching Live View mode off and on again, the last displays selected are active again, but not the enlarged detail.
- Switching the camera off and on again displays the last detail selected.

Release button (31)

1. Pressing briefly activates the range and exposure metering systems. When the release button is pressed, the metering systems remain active for approx. 12 s.

Note:

- If Play mode was previously active, the camera switches back to Capturing mode when the release button is pressed; if it was previously in Stand-by mode, it is activated again by pressing the release button, i.e. the metering systems and displays are activated.
- The release button remains blocked
 - if the internal buffer memory is temporarily full, e.g. after a series of pictures, or
 - if the inserted memory card(s) is/are full.

2. Pressing the release button to the pressure point and holding in this position when using Autofocus **AFs** mode (focus priority), the focus is saved at the same time. New measurements can be performed once the release button is released.

Note:

- The metered exposure value during spot and center weighted metering in **A**, **T** and **P** modes is saved, if required, by (simultaneously) pressing the Joystick forwards. Automatic focusing can also be allocated to the Joystick via the menu control.
3. If the release button is pressed further, the photo is taken or a preselected self-timer delay time starts.

Picture Series

With all Leica S lenses, the Sinarback S 30|45 offers you the choice between manual or automatic distance setting. The autofocus system determines the distance to the subject details in the middle of the image field; this area is marked with a crosshair, in Live View

mode, and in the monitor.

With the Sinarback S 30|45, the picture series can be taken with a frame rate of approx. 3.5 fps.

Setting and using the function

4. In the menu, under **CAMERA**, select the item **Drive Mode** and
5. select **Continuous** in the sub-menu
6. The further function is then determined by the different actuation of the shutter button:
 - Image series are taken as long as the release button is hold fully depressed (and the capacity of the buffer memory and/or memory card(s) is sufficient).
 - If the release button is fully depressed just briefly, the camera continues to take single images.

Interval Shooting

For image series of sequences extending over a prolonged period of time, the Sinarback S 30|45 offers interval shooting. Intervals consist of a defined total number of images and a defined period of time between the images.

Setting and using the function

1. In the menu, under **CAMERA**, select the item **Drive Mode** and
2. select **Interval** in the sub-menu
3. Call up the sub-menu belonging to the interval and
4. there select **Frames** or **Interval Time**
 - In both cases a further sub-menu appears with a numerical keypad. The activates field is highlighted in each case.
5. Select the (first) desired digit by turning the thumbwheel or by pressing the Joystick up, down, to the left or to the right; in the **Frames** sub-menu for the total number of images, in the **Interval Time** sub-menu for the desired time interval between the individual images – in hours/minutes/seconds.
 - To save a digit – to the line above the numerical keypad – press

the thumbwheel or the Joystick forwards. Up to 4-digit numbers can be used; repeat steps 5. and 6. for the second, third and fourth digits. Further functions of this sub-menu:

- ↶ (top right) = Back to the previous menu level without saving the inputs
- **OK** (bottom right) = Confirm inputs and return to the previous menu level

6. Confirm your settings by pressing the button marked **OK** in this case at the bottom right next to the monitor

Note:

- If step 7. is performed without entering a digit in the line, the camera automatically sets the numbers of the factory setting.

7. Interval shooting is started by pressing the shutter button.

Note:

- The function remains active until it is deactivated again in the menu.

Notes applying equally for photo series and interval shooting:

- The camera's buffer memory allows only a limited number of pictures in series. At the pressure point of the release button or during a series of pictures, the number of pictures possible or still possible in the series is displayed in the monitor. Regardless of how many pictures have been taken in a series, both review modes initially show the last picture in the series or the last picture in the series saved on the currently active card, if not all of the pictures in the series have been transferred from the internal buffer memory to the respective card yet.

Details of how to select the other pictures in the series and further options in review mode are described in the respective sections.

Live View mode with Industrial Box

Live View mode permits continuous viewing of the subject on the monitor, i.e. both before and during capturing. Live View mode is switched on and off, and video mode is switched on (without starting recording) with the LV button (3). Pressing the button displays the functions in turn (in an endless loop)

Live View photo / video mode / conventional photography mode

- When switched on, the functions of the adjacent buttons are displayed for 3 seconds in the four corners of the monitor image.
- The Live View mode is always performed using the monitor image.

Notes:

- Additional autofocus and exposure metering function variants can be used during Live View mode, see the corresponding sections.
- Live View mode is based on the image captured by the sensor. To use it, the shutter must be open and it is closed and re-cocked when the function is “cancelled. Of course, this is audible and may result in a delay in the shutter release.
- Frequent use of the Live View mode results in increased power consumption.







Exposure simulation

In the factory setting, the Live View monitor image shows the subject in the brightness resulting from the respective exposure setting. This exposure simulation allows the effect on the picture to be assessed before the photograph is taken, e.g. during exposure corrections or during manual setting of the exposure. With automatic exposure control (P, A, T), on the other hand, the monitor image generally remains equally bright, i.e. within the respective setting ranges. The exposure simulation can be deactivated by pressing the depth of field preview button so that you generally get a monitor image with constant brightness, irrespective of the exposure settings. The “gen-

erally” constant brightness presupposes, however, that the subject brightness and the set exposure do not result in any excessively high or low brightness values, and that the internal exposure time is not longer than 1/30s.

Displays in Live View mode

With the standard setting, the Live View monitor image contains the following displays (see “The displays / In the monitor / Recording mode Live View photo”, p. 59):

- In the corners of the picture, symbols for the functions of the buttons alongside the monitor:  = Review,  = Change of display,  = Magnify and  = Menu
-  Spot autofocus metering eld (+ autofocus metering crosshair)
-  Autofocus metering crosshair
 - Exposure simulation
 - or  = Key lock

Display settings

Repeatedly pressing the button bottom right calls up various additional displays/information in turn:

- Histogram and clipping indicators
- Marking of clearly focused subjects
- Grid lines and horizon
- Extended picture data
- Back to the normal

Histogram

The histogram depicts the brightness distribution in the picture. The horizontal axis shows the brightness values from black (left) through gray to white (right). The vertical axis corresponds to the number of pixels at each brightness level. This form of representation – together with the impression of the picture itself – provides an additional quick and easy assessment of the exposure setting.

Clipping displays

These displays indicate the picture areas without marking.

Setting the function

1. In the menu, under **SETUP**, select the item **Capture Assistants** and
2. select **Exposure Clipping** in the sub-menu
3. In the sub-menu select **Lower Limit** or **Upper Limit**, and
4. set the desired threshold values on the scale by turning the thumbwheel or by pressing the Joystick to the left or right
 - The scale shows the clipping areas relative to the overall exposure

The following then appears in the pictures:

- Excessively light areas are indicated in red, excessively dark areas in blue, flashing in each case. The clipping symbol ([]) also appears in the top right corner.

Notes on the histogram and the clipping indicators:

- Both are available also in Play mode.
- Both always refer to the currently displayed detail (see “Enlarging the Live View monitor image”).

Marking of clearly focused subjects (focus peaking)

In Live View mode, the Sinarback S 30|45 can mark subjects imaged with optimum focus in the monitor picture by highlighting their contours. This simplifies their recognition and hence in particular the manual setting of the focus. The three available colors permit adaptation to any background.

Setting the function

1. In the menu, under **SETUP**, select the item **Capture Assistants** and
2. select **Focus Peaking** in the sub-menu
3. Call up the sub-menu, and
4. select the desired color there
 - All subject details that are in focus at the set range are indicated by outlines in the selected color.

Further information on setting the focus can be found in the corresponding sections.

Note:

When using high ISO values and/or slow shutter speeds, the function may not work.

Important:

This function is based on the subject contrast, i.e. light/dark differences. Therefore, subject details that are not completely in focus but have a high contrast may also be marked.

Grid

The Sinarback S 30|45 offers you two variants of grid lines as an aid to picture composition.

Setting the function

1. In the menu, under **SETUP**, select the item **Capture Assistants**,
2. select **Grids** in the sub-menu, and
3. select **3x3** or **6x4** in the sub-menu
 - If the view with horizon and grid is selected, the selected grid is displayed in the monitor.

Masking

In addition to the standard aspect ratio (2:3) for photos, three further ratios are available when using the DNG format: 1:1, 16:9, 2:1. They open up further composition possibilities while taking the picture.

Setting the function

1. In the menu, under **SETUP**, select the item **Capture Assistants**,
2. select **Photo Masks** in the sub-menu, and
3. select the desired format there
 - The monitor picture is masked accordingly, with 1:1 left and right, with 16:9 and 2:1 top and bottom. While taking the photograph the mask is transparent, during review of corresponding photos in the camera it is not.

Note:

Irrespective of the aspect ratio selected, the whole 2:3 image field is always recorded, i.e. the masking of the monitor picture affects only

the display in the camera. Although the photo is initially displayed with the selected aspect ratio in image processing programs, it is possible to delete the masking there so that the whole 2:3 image field is available again.

Enlarging the Live View monitor image

Select differently enlarged details:

Press the button bottom left repeatedly

- This gives in turn
 - Double the size
 - Four times the size
 - Back to normal size
- The buttons are not displayed with the enlarged view; a frame appears in the bottom left-hand corner that indicates the position of the detail in the picture.

To shift the detail:

Press the Joystick left, right, up or down

Notes:

- The grid line display is not available with the enlarged view.
- After switching Live View mode off and on again, the last displays selected are active again, but not the enlarged detail.
- Switching the camera off and on again displays the last detail selected.

Distance setting

With all Leica S lenses, the Sinarback S 30|45 offers you the choice between manual or automatic distance setting. The autofocus system determines the distance to the subject details in the middle of the image field; this area is marked with a crosshair, in Live View mode, and in the monitor.

Note:

The metering system operates passively on the basis of contrasts, i.e. differences in light/dark in the part of the subject being photographed. It is therefore dependent on a certain minimum brightness and contrast in the subject.

Setting the operating mode

1. In the menu, under **CAMERA**, select the item **Focus Mode** and
2. select the desired option in the sub-menu

Manual setting - MF

Turn the distance setting ring on the lens so that your subject or the most important part of the subject is fully in focus, in Live View mode on the monitor.

In Live View mode you can call up an enlarged detail as a setting aid.

1. In the menu, under **SETUP**, select the item **Capture Assistants**,
2. select **Manual Focus Assist** in the sub-menu, and
3. select **On** or **Off** there
 - If the function is activated, a central detail magnified 4x is displayed briefly each time the setting ring on the lens is turned. The detail can be moved using the Joystick.

Notes:

- Autofocus mode can be activated at any time also with manual setting of the focus using the Joystick (see next section and the section on the function of the Joystick on page 37).

AFs (single) = focus priority

The part of the subject you are aiming at will come into focus.

- After that, the process ends and the setting is saved even if you continue to hold the shutter release button at the first pressure point.
- It is not possible to take an image before it comes into focus, even if the release button is pressed all the way down.

Note:

An AF setting can be stored not only with the release button, but also with the Joystick.

AFc (continuous) = shutter release priority

The parts of the subject being photographed are fully focused.

- The process continues as long as the shutter release button is held at the first pressure point. While the button is being held down the Sinarback's settings are corrected, so other objects at other distances may be recognized by the metering system, or if the distance to the Sinarback of the part of the subject being photographed changes.
- A setting can only be saved by pressing the Joystick forwards.
- Even if no part of the subject is in focus, a picture can be taken at any time.

Note:

You can intervene manually at any time even during autofocus mode by turning the setting ring on the lens.

- In Live View mode the color of the metering crosshair in the monitor changes from red to green when the focus has been correctly set.

Moving the autofocus metering field in Live View mode

In Live View mode, the metering field can be moved to any point of the image field with the Joystick. In the two enlarged details, the detail is first moved together with the metering field that remains in the middle. Only when the detail reaches the edge of the image field can the metering field be moved to the edge of the detail by pushing further.

Note:

If Spot is used as exposure metering method in Live View mode, its metering field is coupled to that of the autofocus, i.e. both metering fields are then moved.

EXPOSURE METERING

Exposure metering methods

The Sinarback S 30|45 offers three different exposure metering methods.

Setting the function

1. In the menu under **CAMERA**, select the item **Exp. Metering**, and
2. select the desired option in the sub-menu

Spot metering

Only the middle of the image field is scanned and evaluated for spot metering. In Live View mode, spot metering is linked to the autofocus metering, i.e. moving the AF metering point also affects the spot metering field.

Center weighted metering

This metering method takes account of the entire image field, although the parts of the subject in the center have more influence on the exposure than the areas at the margins.

Multi-field metering

This metering method is based on detection of five metered values. One is metered in a field in the middle of the image, the other four in the surrounding fields. The five metered values are used in an algorithm to calculate an exposure value appropriate to the situation, resulting in correct reproduction of the assumed main subject.

Exposure Control

The four exposure modes automatic program (P), aperture priority (A), shutter speed priority (T) and manual exposure control (M) are selected on the Sinarback S 30|45 with the thumbwheel:

Setting the operating mode

1. Hold the thumbwheel depressed (for longer than 1 sec.)
 - In the monitor, the large letter (**M**, **A**, **T**, **P**) indicating the set operating mode replaces the normal display. Arrows to the left and right indicate the further settings.
2. Turn the thumbwheel (all four operating modes can be reached in both directions)

Settings for aperture and exposure time are made with the thumbwheel. Half-steps are available. In order to change between aperture and exposure time briefly press the thumbwheel.

The settings of shutter speed and aperture are made by turning the thumbwheel and/or the shutter speed setting dial. In both cases half-steps are available.

In the factory setting, turning the thumbwheel to the right decreases the aperture settings, turning to the left increases the settings. This can be reversed, if desired.

Setting the function

1. In the menu, under **SETUP**, select the item **Customize Controls** and
2. select **Rear Wheel Direction** in the sub-menu
 - A further sub-menu appears.
3. In this sub-menu, select the desired direction of rotation

The function of the thumbwheel can be deactivated for complete protection against inadvertent changing of operating mode, shutter speed, aperture, etc., i.e. turning and pressing do not change the settings in capturing mode.

Setting the function

1. In the menu, under **SETUP**, select the item **Keylock** and
2. select **Off** or **On** in the sub-menu
 - If **On** is selected, the locking key symbol appears in the monitor

Automatic Program Mode -P

Exposure time and lens aperture are automatically set according to the prevailing light and steplessly between 125 s, 1/1000 s.

Displays on monitor

- **P** for the selected exposure operating mode, and
- the automatically controlled shutter speed and aperture values.

Notes:

- If the automatic sensitivity setting (**ISO Auto**) is activated at the same time, the control range of automatic program mode is extended. Even with fully open aperture, however, the shutter speed is only extended beyond the value dictated by the 1/f1 setting selected in the menu when the highest set sensitivity is reached.
- With very little light or extreme brightness it is possible that the available shutter speed range is no longer sufficient for the pre-selected aperture value. In such extremely rare cases a warning symbol for underexposure appears in the viewfinder (possibly also as a warning of values below the metering range, see also "Values below the metering range"), or a warning symbol for overexposure. Correct exposure metering is then no longer possible.

Metering memory lock

The shutter button and/or the Joystick can be used to save the exposure setting (for **P**, **A** and **T**) and the automatic focus (**AF**), depending on the various menu settings.

General notes on the storage function

• With the release button:

- The storage function of the release button always applies to only one picture.

• With the Joystick:

- The exposure and **AF** settings can be stored. Various function combinations are available which you define via the menu control.
- The storage function of the Joystick is retained as long as it is held pressed forward, i.e. over any number of pictures, and regardless of whether the release button is also pressed at the same time.

Saving with the release button

1. Focus on the part of the subject to be metered with the crosshair in the viewfinder
2. Press the release button to the first pressure point. The value stored is retained as long as this pressure point is held.
3. While holding the pressure point, determine the final picture detail and take the
4. picture.

Metering memory lock is canceled when you remove your finger from the release button pressure point.

Saving with the Joystick

Setting the function combinations

1. In the menu, under **SETUP**, select the item **Customize Controls** and

2. select **AFAE Lock Button** in the sub-menu

- A further sub-menu appears.

In this sub-menu select whether you wish to set the function for **In AF Mode** or **In MF Mode** set via the menu

In AF mode

3. In the **AF-Mode** sub-menu, select one of the three variants

Effect of the three function variants:

- **AFAE lock** (factory setting)
 - release button: **AFs** setting
 - Joystick: Exposure setting, **AFs/AFc** setting
- **AE-L**
 - release button: **AFs** setting
 - Joystick: Exposure setting
- **AF-L**
 - release button: **AFs** setting
 - Joystick: **AFs/AFc** setting

In MF mode

In manual focus mode you can nevertheless activate AF mode temporarily, i.e. for the particular picture, and/or – depending on the setting – to save the exposure setting by pressing the Joystick forwards.

3. In the **MF-Mode** sub-menu, select one of the five variants

Effect of the five function variants

- **AFs On / AE Lock** (factory setting)
AFs mode activated for one picture, saving of the exposure setting
The resulting AF setting remains stored until it is changed by manual adjustment or by pressing the button again.
- **AFs on**
- As for **AFs On / AE Lock**, but without saving of the exposure setting
- **AFc On / AE Lock**

As for **AFs On / AE Lock**, but with **AFc** mode

- **AFc on**

As for **AFs On / AE Lock**, but without saving of the exposure setting

- **AE-L**

Saving of the exposure setting

Displays during saving of the exposure setting

- A light balance appears showing the deviation from the stored metered value.
- If aperture and/or exposure time are changed during this time, the respective other value is adapted accordingly and displayed.

Exposure compensation

Exposure compensations are possible in automatic program, shutter speed priority and aperture priority modes.

Entering and canceling an exposure compensation

1. In the menu under **CAMERA**, select the item **Exp. Compensation**.
 - The sub-menu shows a scale with a setting mark highlighted in red. If it is at a value of **0**, this means that the function is deactivated.
2. Set the desired value by turning the thumbwheel or by pressing the Joystick to the left or right.
 - In the initial menu list, a set compensation is indicated by **EV+X**

Note:

In the factory setting, this function can be called up directly by holding the button bottom right depressed.

The following is displayed in the Live View mode in the monitor (in the image data display)

- The compensation value on the light balance
- A corresponding warning symbol
- **+** or **-**

Example, either plus or minus, "X" stands for the respective value

Capturing / Recording Mode

Notes:

- Once set, a compensation value is retained even when the
- Sinarback is switched off.
- An exposure compensation set on the Sinarback only influences metering of the available light, i.e. not flash light (for more information about flash photography, refer to the respective sections).

Manual setting of aperture and exposure time - M

Setting the operating mode

1. Select **M** with the thumbwheel (see also p. 36, “Exposure control”)
2. Set the desired aperture and exposure time by turning the thumbwheel.

Displays in Live View mode

- M for the selected exposure operating mode,
- The manually set aperture and shutter speed values, and
- A light balance with which the exposure compensation is performed. The light balance shows the deviation of the shutter speed/aperture combination just set from the metered exposure value. In the range of ± 3 EV, the deviation is shown clearly in $1/2$ EV steps. Larger deviations are indicated by flashing of the outer mark of the light balance.

For correct exposure according to the exposure meter, vary the aperture and/or speed until only the zero mark of the light balance lights up.

Note:

If the automatic sensitivity setting (**ISO Auto**) is activated at the same time, the last manually set sensitivity is used. A minimum shutter speed that may have been set, however, is not active.

Bracketing

Bracketing can be employed with all four exposure operating modes. The following are available:

- 2 numbers of pictures: 3 or 5
- Graduations: 0.5EV, 1EV, 2EV and 3EV

Setting the function

1. In the menu under **CAMERA**, select the item **Exp. Bracketing**
 - The sub-menu appears on the monitor with the four items **Exp. Bracketing**, **Frames**, **F-Stops** and **Automatic**, and below this a scale. If an exposure compensation is set at the same time, this is indicated by a corresponding value below the scale.
2. For **Exp. Bracketing**, turn the thumbwheel or press the Joystick to left or right to select whether you wish to carry out bracketing (**On**) or not (**Off**)
 - If **On** is selected, the other three sub-menu items are activated (= white).
3. Press the thumbwheel or the Joystick forward to call up the next sub-menu item (the same applies to all sub-menu items)
4. In **Frames**, set the number of frames, and in **F-Stops** the desired exposure graduations between the pictures of the series
 - The selected exposures are displayed in red on the scale. An exposure compensation that may be set is recognizable from the fact that the whole series around the compensation value is “offset” from the middle of the scale.
5. In **Automatic**, select whether you wish to trigger the pictures individually yourself (**Off**), or whether the pictures should all be taken in series when the shutter button is pressed once (**On**)
 - A set exposure series is indicated in the initial menu list by **X / Y EV1**.
6. All pictures are produced by pressing the release button once or several times.

Note:

The function **Exp. Bracketing** is not available if an interval shooting series has previously been set.

Displays in the monitor (in the picture data display)

- A symbol indicating an exposure series

Notes:

- Depending on the exposure mode, the exposure graduations are created by changing the shutter speeds and/or apertures.
- The sequence of the exposures is: Overexposure(s), correct exposure, underexposure(s).
- When using automatic bracketing, all **ISO Auto** settings are fixed:
 - The sensitivity automatically determined by the camera for the uncorrected picture is also used for all other pictures in a series, i.e. this ISO value is not changed during a series.
 - The settings in the **AUTO ISO** sub-menus have no influence, i.e. the full shutter speed range of the camera is available.
- Depending on the initial exposure setting, the working range for automatic bracketing may be limited.
- Regardless of this, the specified numbers of pictures are always taken, which may mean that at the end of the working range, several pictures in a series have the same exposure.
- The function remains active until it is deactivated again in the menu or the camera is switched off.

Values above and below the metering range

If the values are below the metering range of the Sinarback, exact exposure metering is not possible. The metered values that may then be displayed on the monitor can result in incorrect exposure results. For this reason the display **L** always appears on the monitor if the values are below the metering range.

Note:

If the values are above and below the metering range, the time or aperture value on the monitor flashes.

Notes:

- The longest possible exposure time depends on the set sensitivity.
- Long exposure times can be associated with picture noise. To reduce this annoying phenomenon, the Sinarback S 30|45 automatically takes a second “black picture” (taken with the shutter closed) after pictures with slow shutter speeds. The noise present in this parallel picture is then digitally “subtracted” from the data for the real picture.
- This doubling of the “exposure” time can be significant at longer exposure times, and must be allowed for. During this time the Sinarback should not be turned off.
- With shutter speeds slower than 1/2s, the message **Noise Reduction** appears in the monitor.

Taking photographs with the self-timer

You can use the self-timer of the Sinarback S 30|45 to take a picture with a delay of either 2 or 12 s.

Setting / performing the function

1. In the menu, under **CAMERA**, select the item **Drive Mode** and
2. select the required delay time in the sub-menu
3. To start the process, press the release button (see also “Release button”)

Note:

During the delay time, the delay time can be restarted, i.e. prolonged, by pressing the release button again.

Procedure

With 2 s delay time:

Exposure metering is performed first, in autofocus mode the focus is adjusted. Only then does the delay time start.

With 12 s delay time:

The delay time starts immediately after the release button is pressed.

Displays

The running delay time is displayed:

- In the monitor by the display **Capture in 12s** and the countdown of the remaining time until the picture is taken.

Aborting the function

A running self-timer delay time can be aborted by turning off the Sinarback at the main switch.

A running 12 s self-timer delay time can also be aborted during the first 10 s by pressing any of the four buttons next to the monitor.

If the self-timer is no longer to be used, it must be switched off in the menu, as even switching off the Sinarback does not cancel the setting of this function.

Note:

If the self-timer function is set, the shutter is always actuated after the selected delay time, i.e. without the release button having to be pressed again.

ADDITIONAL FUNCTIONS

User / application-specific profiles

On the Sinarback S 30|45, any combination of menu settings can be permanently stored, e.g. so that they can be retrieved quickly and easily at any time for recurring situations / subjects. A total of four memory slots are available for these combinations, as well as a factory default setting that can be retrieved at any time and cannot be changed. You can change the names of the saved profiles. Profiles set on the Sinarback can be transferred to one of the memory cards, for example for use in other Sinarback units, while profiles stored on a card can be transferred onto the Sinarback.

Saving settings / Creating a profile

1. Set the desired functions in the menu
2. In the menu, under **SETUP**, select the item **User Profiles** and
3. select **Save as User Profile** in the sub-menu
 - A further sub-menu appears with four lines for the available profile slots.
4. In this sub-menu, select the desired memory slot
 - A corresponding confirmation prompt appears
5. Confirm **Yes** or cancel **No** your selection there
 - The sub-menu from step 4. appears again, and the selected memory slot is marked as occupied.

Selecting a profile

1. In the menu, under **SETUP**, select the item **User Profiles** and
2. select **Load Profile** in the sub-menu
 - A further sub-menu appears with five lines, the first for the factory settings, the others for the four profile slots.

Only the lines with occupied profiles can be called up.
3. In this sub-menu, select the desired profile
 - The selected profile is marked as **active**.

Note:

If you change one of the settings for the profile currently in use --- appears instead of the name of the profile you were previously using in the initial menu list.

Renaming profiles

1. In the menu, under **SETUP**, select the item **User Profiles**, and
2. select **Rename User Profile** in the sub-menu
 - A further sub-menu appears with four lines for the profile slots.

Only the lines with occupied profiles can be called up.

3. Select the desired profile
 - A keyboard sub-menu is displayed.
4. First delete the existing designation in the title line there, then select the desired characters
 - Turning the thumbwheel or pressing the Joystick to left or right allows each character to be selected in an endless loop.
 - Pressing the Joystick up or down allows you to move between lines.
 - Pressing the thumbwheel or the Joystick forward copies the selected character to the title line.
 - Special "buttons":

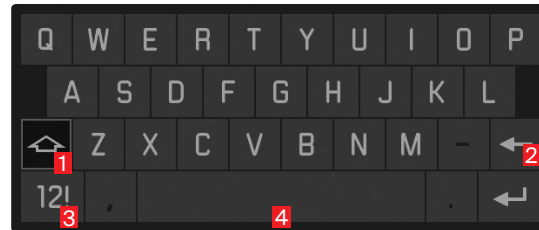

- 1 Switch between capital and small letters
- 2 Delete characters
- 3 Switch between letter and number, or punctuation marks and special characters
- 4 Spacebar

5. Confirm your inputs with the function keys marked **OK** or **OK** to the top right or bottom right of the monitor
 - The sub-menu from step 2. appears again, the edited profile has the new designation.

Saving profiles to a card / transferring profiles from a card

1. In the menu, under **SETUP**, select the item **User Profile** and
2. select **Import from card** or **Export to Card** in the sub-menu.
 - A corresponding confirmation prompt appears
3. Confirm there that you really wish to import or export the profile.

Note:

When exporting, all profile slots are transferred to the card, i.e. including any empty profiles. As a result, when importing profiles any existing profiles in the Sinarback will be overwritten, i.e. deleted.

Resetting all custom settings

This function allows you to delete all previous custom settings in the menu at once, and to reset them to the factory default settings.

Setting the function

1. In the menu, under **SETUP**, select the item **Reset Camera** and
2. select **No** or **Yes** in the sub-menu.

Note:

This reset also applies to the profiles that may have been created and saved with **Save as User Profile** (see left column).

Folder management

The image data on the memory cards is stored in folders which are created automatically. The folder names always consist of eight characters - three digits and five letters. In the factory default setting, the first folder is named "100SINAR", the second "101SINAR", etc. The next free number is always assigned as the folder number; a maximum of 999 folders are possible. If the number capacity is exhausted, a corresponding warning message appears in the monitor. The individual pictures are given continuous numbers up to 9999 unless a the memory card in use already contains a picture with a higher number than the last number assigned by the Sinarback. In such cases, the numbering used on this card is continued. If the current folder contains picture number 9999, a new folder is created automatically and the numbering begins again at 0001. If folder number 999 and picture number 9999 are reached, a corresponding warning message appears in the monitor and the numbering must be reset (see below). With the Sinarback S 30|45 you can also create new folders at any time, give them names of your choice and change the file names.

Create new folder / Assign names of your choice

1. In the menu, under **SETUP**, select the item **Image Numbering** and
2. select **New Folder** in the sub-menu
 - A keyboard sub-menu appears with the folder names in the title line (initially always "XXX SINAR").
3. First delete the existing designation in the title line there, then select the desired characters
 - The procedure corresponds exactly to step 4. under 'Renaming profiles' on p. 41.
4. Confirm your inputs with the function keys marked **OK** to the top right or bottom right of the monitor
 - A corresponding confirmation prompt appears.
5. Confirm **Yes** or cancel **No** your settings there
 - The keyboard sub-menu appears again.

Note:

If memory cards are used that were not formatted with this camera (see next section), the camera automatically creates a new folder.

Resetting picture numbers

The picture numbers can also be reset without having to create a new folder first.

1. In the menu, under **SETUP**, select the item **Image Numbering** and
2. select **Reset** in the sub-menu
The keyboard sub-menu appears.
3. Make the desired settings there

The procedure corresponds exactly to that described in the previous section under 3. - 5.

Changing file names

1. In the menu, under **SETUP**, select the item **Image Numbering** and
2. select **Change Filename** in the sub-menu.
 - A keyboard sub-menu appears with the file names (initially always S100 001).
3. Make the desired settings there
The procedure corresponds exactly to that described in step 4. under 'Renaming profiles' on p.41.
 - The sub-menu from step 2. appears again, the edited file name has the new designation.

Formatting the memory cards

It is not normally necessary to format (initialize) memory cards that have already been used. If an unformatted card or a card formatted in a different device (e.g. a computer) is used for the first time, it has to be formatted.

Important:

Formatting does not necessarily and irrevocably delete all the data on the card. It may be possible to access some of the data again using appropriate software. Only the data that is then overwritten by saving new data is actually permanently deleted.

Notes:

- Do not turn the Sinarback off while memory cards are being formatted.
- If the memory card has been formatted in another device, such as a computer, you should reformat it in the Sinarback S 30|45 .
- If a memory card cannot be formatted, you should ask your dealer for advice.
- Formatting of memory cards deletes even delete-protected pictures (see p. 52).

Setting the function

1. In the menu, under **SETUP**, select the item **Format Cards** and
2. select in the sub-menu which of the two cards you wish to format, or whether you wish to format both
 - A corresponding confirmation prompt appears on the monitor to prevent inadvertent deletion.
3. Confirm **Yes** or cancel **No** your selection there

Marking the picture files for copyright protection

The Sinarback S 30|45 enables you to mark your picture files by entering text or other characters. You can enter up to 17 characters under 2 headings for each picture.

1. In the menu, under **SETUP**, select the item **Copyright Information**
 - The sub-menu containing the three options **Copyright**, **Information** and **Artist** appears in the monitor. Only the **Copyright Information** line is initially activated.
2. Activate the **Copyright** function.
 - The **Information** and **Artist** lines are activated.
3. Select **Information** or **Artist**, and
 - The keyboard sub-menu appears in both cases.
4. Make the desired settings there

The procedure corresponds exactly to that described in section “Resetting picture numbers” in steps 3./5.

 - The sub-menu from step 2. appears again.

Capturing / Recording Mode

Flash mode

There are two ways to connect a studio flash system to Sinarback S 30|45.

Connection via the the Lemo® Multisync socket (13)

- All flash units and studio flash systems that allow control via corresponding special cables

Connection via the flash synchronization socket (7) ⚡

- Studio flash systems and other flash units with flash cable and standard flash plug

Note:

In combination with Sinar eShutter the studio flash system is connected to Sinar eShutter Control. Please refer to the eShutter manual.

Video recordings

The Sinarback S 30|45 can also be used to make video recordings.

Notes:

- As only part of the sensor surface is used, the effective focal length is increased in each case, i.e. the details become correspondingly smaller.
- Uninterrupted video recordings are possible up to a maximum length of 29 minutes.

The following settings are available for video recordings:

Resolution / image frequency

1. In the menu, under **IMAGE**, select the item **Video Resolution** and
2. set the desired resolution in the sub-menu

The two resolutions available have a fixed relationship to different image frequencies. 1080p, for example, can be combined with three different image frequencies in order to match the reproduction to the TV system used: 25 fps for PAL, 24 and 30 fps for NTSC while the 4K resolution is only possible with 24 fps.

Note:

4k video recordings can only be stored on SD cards (see p. 58).

ISO sensitivity

All variants described on p. 24, but **Maximum Auto ISO** for video recordings is set separately in the **Auto ISO Video** sub-menu.

Notes:

- The limitation described below under exposure operating modes applies.
- Vertical and horizontal lines may become visible all over the image, especially when shooting dark subjects with high ISO values containing very bright, spot light sources.

Color space

Video recordings are only possible with sRGB (see p. 27).

Note:

This applies irrespective of a possible deviating setting for photos which remains unchanged.

Constrast, focus, saturation

All variants described on page 22, but they are set separately for video recordings.

1. In the menu, under **IMAGE**, select the item **Video Settings** and
2. select **Video Contrast**, **Video Sharpness** or **Video Saturation** in the sub-menu, and
3. select the desired level/function in the sub-menu

Time code

The time code is a data set that is generated and recorded parallel to the image and audio data. It allows the correct time synchronization of picture and audio signals even after cutting, or after a later separate processing.

You can choose between a continuous 'running'

Timecode – Free Run and a time code for the particular recording – **Rec Run**

1. In the menu, under **IMAGE**, select the item **Video Settings** and
2. select **Timecode** in the sub-menu
3. In the **Timecode** sub-menu select **Timecode Mode** and
4. select the desired function or deactivate the function in the sub-menu

While the time code signal at camera time is always generated and recorded parallel to the video recording, with **Free Run** and **Rec Run** you can define the start yourself, i.e. how large the time offset is to be between the start of recording and the start of time code signal generation. In these two cases, the otherwise inactive second line of the **Timecode** sub-menu can therefore be selected.

5. In the **Timecode Mode** sub-menu select Starting Time and
6. set the delay in the sub-menu
 - Setting the numerical groups (**hh** [hours], **mm** [minutes], **ss** [seconds] and **frame** [frame number within the respective second]): Turn the thumbwheel or press the Joystick up or down
 - Switching between the numerical groups: Press the thumbwheel or the Joystick forwards, to the left or to the right

Capturing / Recording Mode

Exposure metering methods

All the variants described on page 36

Exposure modes

- Aperture priority (is not available if a Sinar eShutter or a Copal shutter is used, see p. 30-31).
- Manual control with shutter speeds of 1/30 - 1/4000s.
Set slower shutter speeds are dealt with in the same way as 1/30s.

Notes:

- If a correct exposure is not possible even with the maximum aperture, the ISO sensitivity is automatically increased, regardless of any manual setting.
- The automatic exposure control takes all brightness fluctuations into consideration. If this is not desired, e.g. for landscape recordings and pans, you should set the exposure manually.

Distance setting

All the variants described on page 35

Starting / Ending the recording

Starting:

Press the video record button (4)

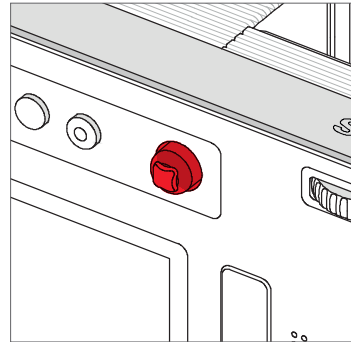

- A video recording in progress is indicated in the monitor by a flashing red dot and the elapsed recording time.
- As video recordings with the Sinarback S 30|45 are made with different aspect ratios, depending on the selected resolution, the monitor image appears with corresponding masking.

Ending:

Press the video record button again

Single pictures during video recordings

Single pictures can be taken during a running video recording. Pressing the release button interrupts the video recording for the duration of the single picture. The individual pictures are taken with the relevant settings on the camera.

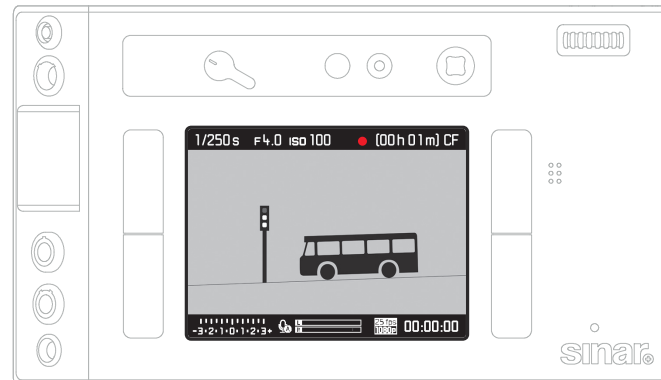

Sound recording

The sound can be recorded using external microphones connected via the optionally available LEMO® audio adapter.

Note:

The automatic distance setting (autofocus) generates noises that are also recorded.

Setting the audio recording level is possible automatically or manually before or during the recording.

1. In the menu, under **IMAGE**, select the item **Video Settings**,
2. select **Audio Level** in the sub-menu, and
3. set the desired function there

Manual setting

1. Hold the Live view (3) button depressed, and
2. press the Joystick to the left (= decrease level) or right (= increase level)

The level should be set so that input override is avoided, i.e. such that the horizontal 'bars' do not or only seldom change from white to red (at the far right end of the scale).

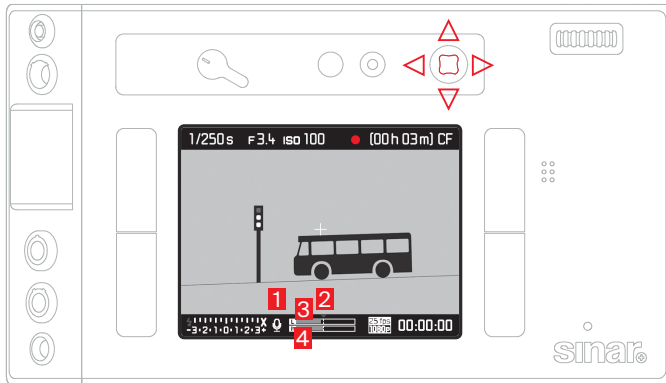

- 1 Microphone (🎤 = Automatic recording level control, 🎧 = Manual recording level control, 🚫 = No sound recording)
- 2 Setting mark
- 3 Left channel level
- 4 Right channel level

Note:

The level is not controlled separately for each channel.

Deactivate sound recording

Move the setting mark completely to the left until the microphone symbol changes from 🎧 to 🚫

To reduce any noise caused by wind during sound recording, a damping function is available.

1. In the menu, under **IMAGE**, select the item **Video Settings**,
2. select **Audio Wind Elimination** in the sub-menu, and
3. activate or deactivate the function there

Note:

When no wind noise is to be feared, you should always select **Off** to ensure optimum sound.

Checking the sound recording

You can check your recording level even during the recording using connected headphones.

1. Connect the headphones to the camera via the LEMO® audio jack using the optionally available Audio adapter S.
 - The corresponding display appears in the monitor image

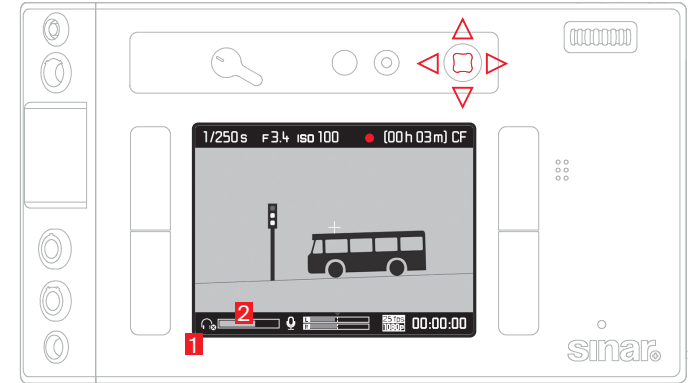

- 1 Symbol for connected headphones
- 2 Volume bar

Setting headphone volume

2. Hold the Live view (3) button depressed, and
3. press the Joystick down (= reduce volume) or up (= increase volume).

REVIEW MODE**Note:**

Two functions are available for the review of your recordings:

- Automatic review after each recording
- Review for unlimited time

Automatic review of last image

In **Auto Review** mode, each image is displayed on the monitor immediately after it is taken. You can set the time for which the picture is to be displayed.

Setting the function

1. In the menu, under **SETUP**, select the item **Auto Review** and
2. select the desired function or time in the sub-menu: (Off, 1 s, 3 s, 5 s, Hold)







Review for unlimited time*Setting the function*

Call up Review mode by briefly pressing the button to the top right of the monitor.

- The last image taken appears in the monitor along with the corresponding displays. However, if the memory card(s) inserted do(es) not contain any image files, the following message appears when you switch to review mode: **No media file to display.**

Displays in Review mode

For undisturbed viewing of the captures/recordings, only the following are displayed during review for unlimited time:

- In the header some fundamental information
- The functions of the adjacent buttons for 3 seconds in the four corners of the monitor picture when switched on:  = Protect menu,  = Change of display,  = Delete menu and  = Menu
- Top right  and  for the functions of the two thumbwheels
- Bottom right  for button lock (if activated)

If the memory card or the selected file cannot be read, a corresponding symbol appears in the right-hand margin of the black picture.

Notes:





- From **Auto Review** mode, you can switch back at any time to normal unlimited PLAY review mode.
- Even pictures that have not yet been transferred from the Sinarback's internal buffer memory to a card – the LED at bottom right on the rear of the Sinarback's is still flashing – can be viewed immediately.
- On the other hand, the images on the cards are not accessible while data are being transferred.
- If the masking function was used during recording (see p. 28), the photo appears with the selected aspect ratio.

- Only image data captured/recorded with a Sinarback S 30|45 can be reviewed with the Sinarback S 30|45.
- If the image data are stored in parallel in JPG and DNG format, the image displayed is always based on the DNG file.
- If photographs were taken with the picture series function or automatic bracketing, the last image in the series is shown first in both review modes.
- To select other images from the series, see p. 50.

Video playback

A video recording can be recognized from the following characteristics:

- Picture format (16:9 with Full HD, approx. 17:9 with 4K)
- Additional video-related information in a footer
- A field with the video and audio control symbols when switching on and each time the Joystick is pressed to the left:

 Louder	= Press up
 Fast forward	= Press right
 Play/Pause	= Press forward
 Quieter	= Press down
 Fast rewind	= Press left

Fast forward and fast rewind start in slow motion and get faster the longer the button is held down in the appropriate direction.

Turning the thumbwheel once to the left or right takes you directly to the beginning or end of a video.

Setting the volume

Press the Joystick down (= reduce volume) or up (= increase volume)

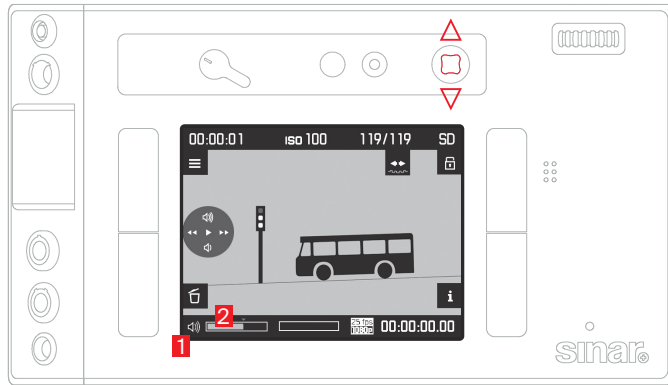

1 Symbol for camera loudspeaker/connected headphones

2 Volume bar; at the far left-hand end of the bar the audio playback is deactivated (🔇/🔊).

Displays in Review mode

For undisturbed viewing of the recordings, only the following are displayed during review for unlimited time:

- In the header some fundamental information
 - The functions of the adjacent buttons for 3 seconds in the four corners of the monitor picture when switched on: = Protect menu, = Change of display, = Delete menu and = Menu
 - Top right and for the functions of the two thumbwheels
- If the memory card or the selected file cannot be read, a corresponding symbol appears in the right-hand margin of the black picture.

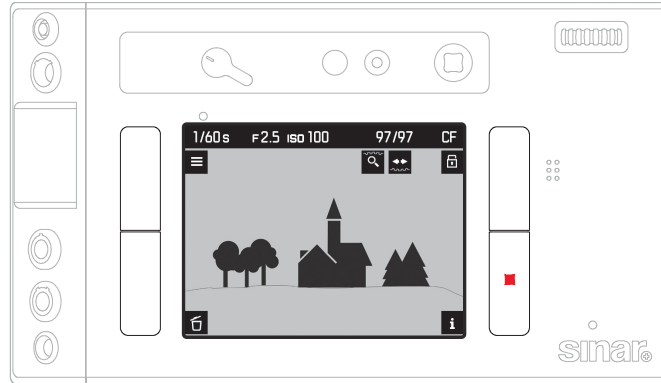

During both the unlimited review and the video payback, various additional displays and information can be called up in turn, in addition to the displays described above, by repeatedly pressing the button bottom right next to the monitor as in Live View mode:

- Histogram and clipping indicators
- Grid lines and horizon
- Extended picture data
- Back to the normal view

The settings for grid lines, histogram and marking of clearly focused subjects are made in exactly the same way as described for Live View mode on pages 30 ff.

Review with histogram and clipping indicators

- Also displayed are:
 - The histogram at top left
 - Areas that are too bright are marked in red, areas that are too dark in blue, flashing in each case, and at bottom right the clipping symbol ()

The clipping displays

You can use the menu to set the clipping thresholds for displaying both the light and dark areas.

Setting the function

1. In the menu, under **SETUP**, select the item **Capture Assistants** and
2. select **Exposure Clipping** in the sub-menu.
3. In the sub-menu select **Lower Limit** or **Upper Limit**, and
4. set the desired threshold values on the scale by turning the thumbwheel or by pressing the Joystick to the left or right.
 - The scale shows the clipping areas relative to the overall exposure range.

Notes:

- The histogram and the clipping indicators are available both during review of the whole picture and during review of a detail, but not
- during the simultaneous review of 4 or 9 reduced pictures.
- The histogram and clipping indicators always relate to the detail of the part of the picture currently being displayed.

Marking of clearly focused subjects

- All clearly focused subjects are marked by highlighted contours.

The four available colors permit adaptation to any background.

1. In the menu, under **SETUP**, select the item **Capture Assistants** and
2. select **Focus Peaking** in the sub-menu
3. Call up the sub-menu, and
4. select the desired color there

Extended picture data

- A wide variety of additional picture data is displayed.

Note:

This review option only allows you to view the entire picture, even if only a section was previously selected.

Viewing other pictures / scrolling

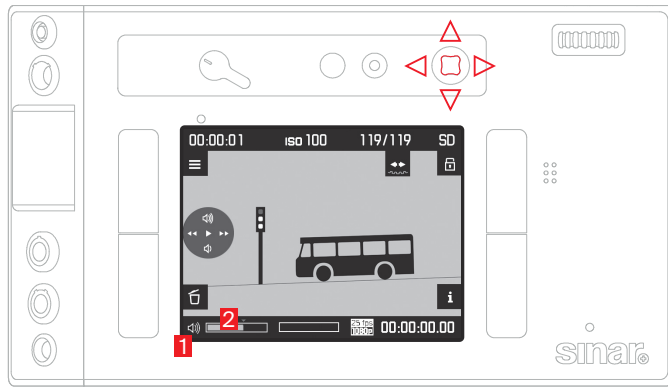

Turning the thumbwheel allows you to select other pictures.

Turning to the left takes you to the pictures with lower numbers, turning to the right to the pictures with higher numbers. After reaching the highest and lowest numbers, the series of the pictures arranged in an endless loop starts again from the beginning so that you can reach all the pictures in both directions.

- The picture and file numbers in the monitor change accordingly.

Note:

This is possible in all review modes, at all zoom levels, including off-center details, and during the simultaneous review of several reduced pictures.

Enlarging the detail

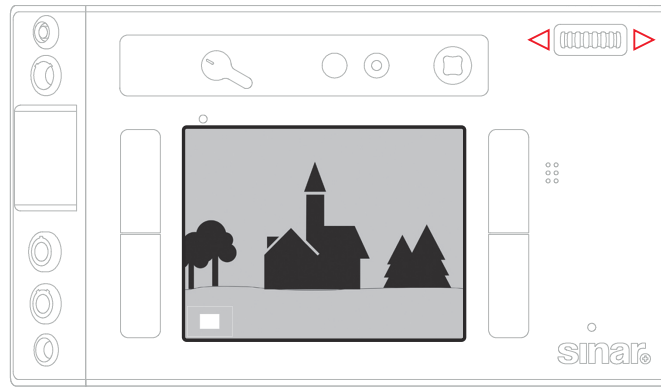

You can enlarge a detail of the picture

- in steps
- or
- call up the highest possible enlargement in one step.

Enlarging in steps

The displayed detail can be enlarged by first briefly pressing the thumbwheel and then turning it to the right. The further you turn, the greater the enlargement and the smaller the detail. Enlargement is possible in 4 steps until 1 pixel of the monitor displays 1 pixel of the picture.

- The displays in the header and the symbols for the functions of the keys and thumbwheels disappear. The rectangle inside the frame shows the size and position of the detail.

Maximum enlargement in one step

Holding the thumbwheel depressed (longer than 1 sec.) switches between the review of the whole picture and maximum enlargement.

Note:

The function is available at all zoom levels. If a detail was previously displayed, pressing the first time displays the whole picture again.

Moving the detail

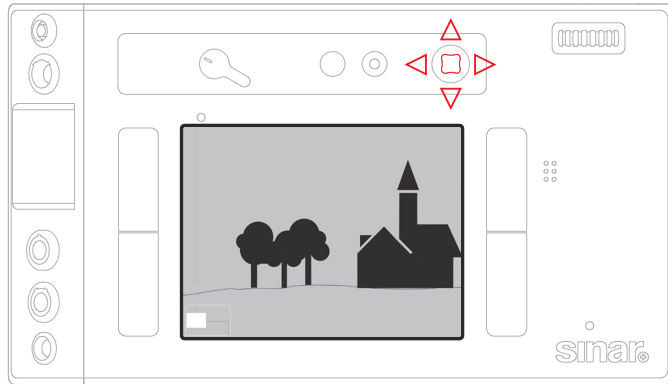

Press the Joystick in the desired direction - up, down, right or left





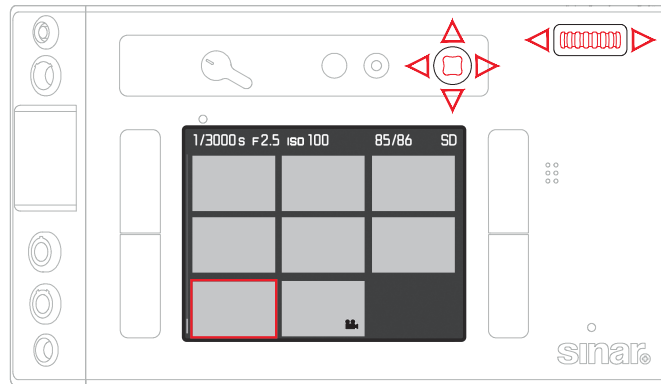

- The rectangle inside the frame moves in the direction the Joystick is pressed.

Selection of one of the (contact sheet)

1. To get an overview of the images, first briefly press the thumb-wheel and then turn it to the left."
2. Select the desired picture by pressing the Joystick up, down, left or right
 - The frame changes to an endless loop in lines from picture to picture.
3. The framed picture can be enlarged in steps by turning the shutter speed setting dial to the right









Protecting pictures / clearing delete protection

- Press any of the button top or bottom left, or top or bottom right of the monitor
 - In the image field the button functions valid in this situation are displayed - for 4 s - alongside the corresponding buttons  (Call up menu control),  (Call up delete menu),  (Call up protect menu) and  (Change display, see page 48)
- Press the button marked  in this case
 - The image field displays:
 - The button functions valid in this situation **ALL**, **Back**, and **OK**, and **Protect single?** in the footer
 - Possibly the symbol  for a delete-protected picture.
- With the button top left of the monitor, select whether you wish to protect only the displayed picture or all the pictures, or (in case one or several pictures are already protected) whether you wish to cancel the delete protection for the displayed picture or all the pictures
 - The corresponding displays change: Alongside the button between **ALL** and **SINGLE**, in the footer according to the situation.

Notes:

- Even when protection or canceling of the delete protection of individual pictures is activated, you can enlarge the picture or call up other pictures.
 - Pressing the button marked **BACK** in this case (see above under 2.) returns you to the respective normal view.
- Press the **OK** button to protect the picture(s) or to cancel the delete protection.
 - The symbol  for a delete-protected picture appears or disappears in the monitor.

Deleting pictures

- Press any of the button top or bottom left, or top or bottom right of the monitor
 - In the image field the button functions valid in this situation are displayed - for 4 s - alongside the corresponding buttons  (Call up menu control),  (Call up delete menu),  (Call up protect menu) and  (Change display, see p. 48)
- Press the button marked  in this case
 - The image field displays
 - the button functions valid in this situation **ALL**, **BACK**, and **OK**, and **Delete single?** in the footer.
 - Possibly the symbol  for a delete-protected picture.
- With the button top left of the monitor, select whether you wish to delete only the displayed picture or all the pictures
 - The corresponding displays change: Alongside the button between **ALL** and **SINGLE**, in the footer according to the situation.

Notes:

- When deletion is activated, you can enlarge the picture or call up other pictures.
- Pressing the button marked **BACK** in this case (see above under 2.) returns you to the respective normal view.

If only one picture is to be deleted

- Press the **OK** button to delete the picture(s).
 - The next undeleted picture appears in the monitor. If this was the only picture a message is displayed: **No media file to display**

If all pictures are to be deleted

- Press the button marked **OK** in this case.
 - A safety confirmation prompt appears on the monitor: **Delete all?**

Notes:

- Pressing the button marked **OK** in this case (see above under 2.) returns you to the respective normal view.
 - Protected pictures are not deleted. After deletion, the last (highest number) of the undeleted pictures appears.
- Confirm and start the deletion with the **OK** button.
 - A message appears in the monitor: **No media file to display.**

ADDITIONAL FUNCTIONS

Transferring data to a computer

The Sinarback S 30|45 is equipped with a USB 3.0 interface for transferring data to a computer. This allows fast data transfer to computers with the same kind of interface. The computer used must either have a USB port (for direct connection of the Sinarback S 30|45), or be equipped with a card reader for CF or SD/SDHC/SDXC cards. Furthermore, an up-to-date USB 3.0 driver must be installed.

If the Sinarback S 30|45 is connected to the computer with the LEMO® USB 3.0 cable (16040), it is automatically recognized by the operating system. Use the Windows® Explorer or Apple® Finder, respectively, to copy/save the picture data to your computer.

Note:

Apple® Mac® computers allow the transfer of video files only up to a maximum file size of 4 GB. If larger video files are copied, an error message is displayed.

Important:

- Use only the LEMO® USB cable supplied (16040).
- While data is being transferred from the Sinarback S 30|45 to the computer, under no circumstances should the connection be interrupted by removing the USB cable, as otherwise the computer and/or the Sinarback S 30|45 may crash, and the memory card may even be irreparably damaged.
- While data is being transferred from the Sinarback S 30|45 to the computer, the Sinarback must not be turned off or turn itself off due to a lack of battery capacity, as otherwise the computer can crash. For the same reason the battery must never be removed from the Sinarback while the connection is active. If the battery capacity is

about to run out during data transfer, stop the data transfer, turn off the Sinarback (see p. 7) and charge the battery (see p. 13).

Transferring the data using card scanners

The picture data can be transferred to a computer using a commercially available card scanner for CF or SD/SDHC/SDXC memory cards. These devices, as well as further information, can be obtained in a computer accessories store.

Data structure on the memory card

The 100SINAR, 101SINAR, etc. folders can each hold up to 9999 pictures.

Installing firmware updates

Sinar Photography AG is constantly working on developing and optimizing its products. As digital camera backs have many functions that are purely controlled electronically, some of these improvements and enhancements to the functions can be installed on the camera at a later date. Sinar Photography AG provides firmware updates at irregular intervals for this purpose. Information about any resulting changes or additions to the details in this manual can be found on www.sinar.swiss/download

You can check in the sub-menu of menu item **Camera Information** whether your Sinarback has the latest firmware version ((see also p. 21 ff).

You can easily download new firmware yourself from our website and install it on your Sinarback.

1. Format a memory card in your Sinarback S 30|45
2. Switch off the Sinarback and insert the card into a card reader – either integrated or connected to your computer. (A card reader is required for firmware updates)
3. Download the firmware file under the link:
4. Save the firmware file to the highest level of the card folder structure.
5. Eject the card properly from your card reader, insert it into the camera and close the cover.
6. Turn on the Sinarback
7. In the menu, under **SETUP**, select the item **Camera Information**
 - If the Sinarback detects a newer firmware version than the one installed, this will be indicated in the respective line by characters (!) in front of the firmware number.
8. Open the corresponding sub-menu
 - Apart from the two version numbers, the sub-menu contains a confirmation prompt.
9. Start the update with **Yes** or reject with **No**
 - A progress screen appears during the process.
 - The update process begins. This can take several minutes.
 - After a successful update, a corresponding message is displayed for confirmation.

Note:

If the battery is not charged sufficiently, a corresponding warning message is displayed.

Additional Functions

Data transmission / Remote control of Sinarback

You can control the Sinarback remotely using a smartphone/tablet or use the smartphone/tablet as an external storage medium. In order to do this, the Sinarback S 30|45 app must first be installed on your smartphone. This app is available in the Apple App Store™ for iOS™ devices.

WLAN settings

1. In the menu, under **SETUP**, select the item **WLAN** and
2. activate **WLAN** Connection in the sub-menu

Create personal password

For security reasons you should change the default password for the connection to your Sinarback S 30|45. The data are encrypted with the WPA2 standard during the data transfer.

1. In the **WLAN** sub-menu, select **Network Key**

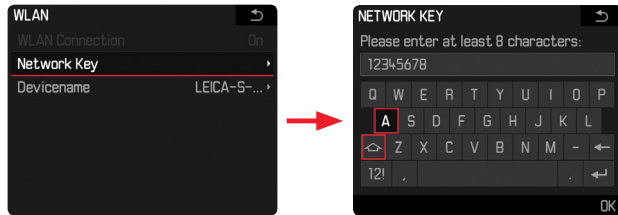

2. Enter the characters for your personalized password using the Joystick or the thumbwheel
3. Press the button marked **OK**

Change device name (SSID)

You can change the device name (SSID) of the Sinarback. A name has already been assigned at the factory (SINARBACK-S).

1. In the **WLAN** sub-menu, select **Device Name**



2. Enter the characters for your personalized device name using the Joystick or the thumbwheel
3. Press the button marked **OK**

Create connection to the Sinarback

(Settings are made at the smartphone/tablet)

1. Select the Sinarback from the list of available WLAN networks
2. Enter the Sinarback password

Data transfer and remote control

1. Start the app on your smartphone/tablet
2. Create connection to the Sinarback
3. Execute the desired function using the app

Notes:

- When using devices or computing systems that require more reliable security than WLAN devices, appropriate measures must be taken to ensure security and protect against disruptions to the systems used.
- Sinar Photography AG accepts no liability for damage arising from the use of the Sinarback for purposes other than as a WLAN device.
- It is assumed that the WLAN function will be used in the countries where this Sinarback is sold. If used in other countries than the one where the Sinarback is sold, there is the risk that communications transmission conditions may be violated. Sinar Photography AG assumes no responsibility for violations of this kind.
- Please also notice that data transmitted and received wirelessly may be intercepted by third parties. We highly recommend that you activate encryption in the wireless access point settings in order to ensure that the information is secure.
- Don't use the Sinarback in places where there are magnetic fields, static electricity, or disturbances, such as near microwaves. Otherwise the wireless transmissions may not reach the Sinarback.
- Using the Sinarback near devices such as microwaves or cordless telephones that use the 2.4 GHz radio frequency wavelength may negatively affect the performance of both devices.
- Do not connect to wireless networks you are not authorized to use.
- When the WLAN function is activated, the device will automatically search for wireless networks. When this happens, networks that you are not authorized to use (SSID: indicates the name used to identify a network over a WLAN connection) may be displayed. Do not attempt to connect to such a network, since this would be seen as unauthorized access.

MISCELLANEOUS

Sinar Back S 30|45 system accessories

Professional charger S

This charger allows you to significantly boost and safeguard the availability of your Sinarback S 30|45 system: It can charge two batteries at the same time. (Order No. 16 011)

AC adapter S (power pack)

If the Sinarback S 30|45 is used in a fixed position and/or for a very large number of pictures over a prolonged period, and particularly when it cannot be monitored, then it is expedient to ensure a continuous power supply by using this AC adapter. (Order No. 16 041)

Note:

The power pack S (Order No. 16 022) cannot be used with the Sinarback S 30|45.

Remote cord S

The electric remote cord S is highly recommended where maximum jitter-free photography is demanded. (Order No. 16 029)

HDMI cable

The HDMI cable allows exceptionally fast transfer of picture data to display equipment with corresponding HDMI sockets. Length = 1.5 m (Order No. 14 491)

Audio adapter S

The audio adapter S that is connected to the camera via LEMO® plug allows the simultaneous connection of headphones and a microphone (both with 3.5 mm jack). (Order No. 16 042)

Spare parts

	Order No.
Li-Ion Battery S BP-PRO1	16 039
Quick Charger S (with integrated USA mains plug and EU, UK and AUS interchangeable mains plugs, car charging cable)	16009

PRECAUTIONS AND CARE INSTRUCTIONS

General Precautions

Do not use your Sinarback S 30|45 in the immediate vicinity of devices with powerful magnetic, electrostatic or electromagnetic fields (e.g. induction ovens, microwave ovens, television sets or computer monitors, video gameconsoles, cell phones, radio equipment).

- If you place the Sinarback S 30|45 on or very close to a television set, its magnetic field could interfere with picture recordings.
- The same applies for use in the vicinity of cell phones.
- Strong magnetic fields, e.g. from speakers or large electric motors, can damage the stored data or the pictures.
- If the Sinarback S 30|45 malfunctions due to the effects of electromagnetic fields then turn the Sinarback off, remove the battery, and then turn the camera on again after reinserting the battery. Do not use the Sinarback S 30|45 in the immediate vicinity of radio transmitters or high-voltage power lines.
- Their magnetic fields can also interfere with picture recordings. Protect the Sinarback S 30|45 from contact with insect sprays and other aggressive chemicals. Petroleum spirit, thinner and alcohol may not be used for cleaning.
- Certain chemicals and liquids can damage the housing of the Sinarback S 30|45 or the surface coating.
- As rubber and plastics sometimes emit aggressive chemicals, they should not remain in contact with the Sinarback S 30|45 for a long time. The Sinarback S 30|45 is protected against moisture and dust to a certain extent by a number of design measures. Ensure nevertheless that neither water, sand nor dust can get into the camera, e.g. when it is snowing or raining or on the beach.
- Sand and dust can damage the Sinarback and memory cards. Take particular care when changing lenses and when inserting and removing the cards. If moisture does get in, it can cause malfunctions and even permanent damage to the Sinarback S 30|45 and the

memory cards. If salt water spray gets onto the Sinarback S 30|45, wet a soft cloth with tap water, wring it out thoroughly and wipe the camera with it. Then wipe down thoroughly with a dry cloth.

Monitor

- If the Sinarback S 30|45 is exposed to significant temperature fluctuations, condensation can form on the displays. Wipe it off carefully with a soft dry cloth.
- If the Sinarback S 30|45 is very cold when it is turned on, the displays may at first appear darker than usual. As soon as they warm up, they will reach their normal level of brightness. The monitor is manufactured using a high-precision process. This ensures that, of the total of around 921,600 pixels, more than 99.995% work correctly and only 0.005% remain dark or are always bright. However, this is not a malfunction and it does not impair the reproduction of the picture.

Sensor

Cosmic radiation (e.g. on flights) can cause pixel defects.

Condensation

If condensation has formed on or in the Sinarback S 30|45, you should turn it off and leave it to stand at room temperature for around an hour. Once the camera temperature has adjusted to room temperature, the condensation will disappear by itself.

Care instructions

- As any soiling also represents a growth medium for microorganisms, you should take care to keep the equipment clean.
-

For the digital camera back

- Clean the Sinarback S 30|45 only with a soft, dry cloth. Stubborn dirt should first of all be covered with a well-thinned cleaning agent and then wiped off with a dry cloth.

- To remove stains and fingerprints, the digital camera back should be wiped with a clean lint-free cloth. Tougher dirt in hard to reach corners of the camera body can be removed with a small brush. Take care not to damage the shutter blades and mirror surface, e.g. with the shaft of the brush.

For the battery

Rechargeable lithium ion batteries generate power through internal chemical reactions. These reactions are also influenced by the ambient temperature and humidity. Very high and low temperatures shorten the operating time and service life of the batteries.

- Always remove the battery if you will not be using the Sinarback S 30|45 for a longer period of time. Otherwise after several weeks the battery could undergo deep discharge, i.e. the voltage is sharply reduced, as the Sinarback S 30|45 still consumes a small amount of current (e.g. for saving date and time) even when it is turned off.
- Lithium ion batteries should only be stored in a partially charged condition, i.e. not completely discharged or fully charged (in the corresponding display in the top panel display). For very long storage periods, you should charge the battery for approx. 15 minutes roughly twice a year to avoid a deep discharge.
- Always ensure that the battery contacts are clean and freely accessible. Whilst lithium ion batteries are proof against short circuits, they should still be protected against contact with metal objects such as paper clips or jewelry. A short-circuited battery can get very hot and cause severe burns.
- If a battery is dropped, check the casing and the contacts immediately for any damage. Using a damaged battery can damage the Sinarback S 30|45.
- Batteries have a limited service life.
- Take damaged batteries to a collection point to ensure correct recycling.
- Never throw batteries into a fire as this can cause them to explode

For the charger

- If the charger is used in the vicinity of radio receivers, it can interfere with the reception; make sure there is a distance of at least 1m / 3,5 feet between the devices.
- When the charger is in use, it can make a noise (buzzing) – this is quite normal and is not a malfunction.
- When it is not in use, disconnect the charger from the mains as otherwise it uses a certain (very small) amount of power even when no battery is inserted in it.
- Always keep the charger contacts clean, and never short circuit them.

For memory cards

- Whilst a picture is being stored or the memory card is being read, it may not be removed, nor may the Sinarback S 30|45 be turned off or exposed to vibrations.
- For safety, memory cards should only ever be stored in the antistatic cover supplied.
- Do not store memory cards where they will be exposed to high temperatures, direct sunlight, magnetic fields or static discharge.
- Do not drop or bend memory cards as this can damage them and result in loss of the stored data.
- Always remove the memory cards if you will not be using the Sinarback S 30|45 for a longer period of time.
- Do not touch the connections on the memory card and keep them free of dirt, dust and moisture.
- It is recommended that the memory cards are reformatted from time to time, as fragmentation occurs when deleting, which can block some of the memory capacity.

Cleaning the sensor

If any dust or dirt particles should adhere to the sensor cover glass, depending on the size of the particles this can be identified by dark spots or marks on the pictures.

The Sinarback S 30|45 can be returned to Sinar Photography AG Customer Service (address: [see p. xy](#)) for chargeable cleaning of the sensor; this cleaning is not covered by warranty.

You can carry out cleaning by yourself while observing the following aspects:

- Dust on the sensor's protection glass can be removed with the help of a blower brush.
- Possible stains caused e.g. by saliva can be removed by carefully using a lint-free tissue (e.g. lens cleaning tissues) that is moisturized with a mild, soapy solution or a lens cleaning solution.

Important:

- Before cleaning with a tissue, make sure all dust has been removed from the glass surface (scratches).
- When cleaning, make sure using only little liquid on the tissue (not dripping).
- Avoid applying pressure on the glass as this could permanently damage the glass surface.

Important:

- Sinar Photography AG accepts no liability for damage caused by the user when cleaning the sensor.
- Do not attempt to blow dust particles off the sensor cover glass using your mouth; even tiny droplets of saliva can cause marks that are difficult to remove.
- Compressed air cleaners with high gas pressure may not be used as they can also cause damage.
- Take care to avoid touching the sensor surface with a hard object during inspection and cleaning.

Notes:

- Generally: To protect the Sinarback S 30|45 against ingress of dust, it is important always to have a cover fitted to the digital back.

Storage

- If you will not be using the Sinarback S 30|45 for a longer period of time, we recommend that you
 - a. Switch it off (see p. 15),
 - b. Remove the memory cards (see p. 12), and
 - c. Take out the battery (see p. 11), (the entered time and date are lost after max. 3 months, see p. 20).
- A lens acts like a magnifying glass if bright sunlight shines on the front of the camera. The camera must therefore never be set aside in strong sunlight without protection. Using the lens cover and keeping the camera in the shade (or immediately putting it away in the case) help to prevent damage to the interior of the camera.
- Store the Sinarback S 30|45 in a dry, adequately ventilated place, where neither high temperatures nor high humidity will occur. When used in humid conditions, the Sinarback S 30|45 should be completely free of all moisture before being stored away.
- Photo cases that became wet during use should be emptied to prevent damage to your equipment caused by moisture and any leather-tanning residue released.
- To prevent fungal growth during use in hot, humid tropical climates, the camera equipment should not be kept in air-tight containers for longer than absolutely necessary. This is only recommended if a desiccant such as silica gel is placed in the container
- In a dry environment, store the Sinarback S 30|45 preferably in a closed and padded container so that nothing can rub against it and it is protected from dust.
- Note the serial numbers of your Sinarback S 30|45 and lenses, as these are extremely important in case of loss.

TECHNICAL DATA

Picture format / aspect ratio 30 x 45mm / 2:3

Image sensor / resolution Leica CMOS sensor with 6 µm pixel size, with micro lenses, 37.5 MP

Dynamic range 15 aperture stops

Color depth 16 bits per pixel

Deep-pass filter None, maximum transfer of sharpness,

Data formats Photo: DNG (raw data), DNG + JPG, JPG DNG /JPG resolution DNG: 37.5 MP, JPG: 37.5 MP, 9.3 MP, 2.3 MP

File size DNG: approx. 42 Mbyte, JPG: approx. 1-16 Mbyte (depending on the resolution used and picture content),

Video: Uninterrupted video recordings are possible up to a maximum length of 29 minutes, maximum file size for transfer to MAC computers: 4 GB

Buffer memory 2 GB, maximum number of pictures in series (depending on memory card used): DNG: max. 14, JPG: unlimited

Color spaces Adobe® RGB, sRGB, ECI RGB 2.0

White balance Automatic, manual by metering, 8 presets, color temperature input

Storage medium CF cards (max. UDMA7), SD cards up to 2 GB, SDHC cards up to 32 GB, SDXC cards, memory cards with a capacity of less than 1 GB cannot be used,

4K video recordings can only be stored on SD cards (only bus type UHS-1 and UHS-2, and bus speed U1 are supported)

Menu languages English, German, French, Italian, Spanish, Russian, Japanese, Traditional Chinese, Simplified Chinese, Korean, Portuguese

Sensitivities ISO100, ISO200, ISO400, ISO800, ISO1600, ISO 3200, ISO6400, ISO 12500, Automatic

Focus detection Using phase detection method, in Live View mode on the basis of contrast

Monitor 3" color TFT LCD monitor with 16 million colors and 921,600 pixels, approx. 100% image field, max. 170° viewing angle, anti-reflex/ anti-soiling protective glass (Corning® Gorilla Glas®), color space: sRGB

Live View mode Optionally with/without exposure simulation, spot metering field can be moved in the whole image field, linked to also freely movable AF metering field, display optionally with histogram and clipping, marking of clearly focused subjects (focus peaking), grid lines and horizon indicators, picture information

Video mode

Format, resolution, frame rate, color scanning MOV (Motion JPG), optionally Full HD (1080 x 1920) with 24, 25 or 30 fps or 4K (2160 x 4096) with 24 fps, 4:2:2

Turning the camera on/off With main switch on camera top panel, optionally auto power off after approx. 2/5/10 minutes

Power supply Rechargeable Li-Ion Battery, rated voltage 7.3 V, capacity 2300 mAh, capacity display in top panel display; charge current / voltage: DC 1250 mA / 7.4 V. Model number: BP-PRO1; Manufacturer: PT. VARTA Microbattery Indonesia; Made in Indonesia, permanent power supply possible using mains power pack (available as an accessory)

Lithium-Ion Battery Charger Quick Charger S; Inputs: 100-240 V AC, 50/60Hz, 200 mA, automatic switching, or 12/24 V DC, 1A; Output: Nominal 7.4 V DC, 1250 mA / max. 8.25 V, 1265 mA Model number: 9C94270; Manufacturer: Ansmann; Made in China

WLAN (802.11n-Standard), Integrated into camera, camera control and picture monitoring possible with smartphone or tablet app

Operating conditions 0 to +45°C, 15%-80% relative humidity

Interfaces HDMI socket Type C, LEMO® jack for data output (USB 3.0 standard), 9-pin LEMO® jack for remote control accessory/ remote flash trigger, audio out/in possible with audio adapter (available as an accessory)

Dimensions (width x depth x height) approx. 165 x 95 x 60 mm
Weight approx. 800 g (with battery)

THE DISPLAYS

In the monitor

Photo recording mode

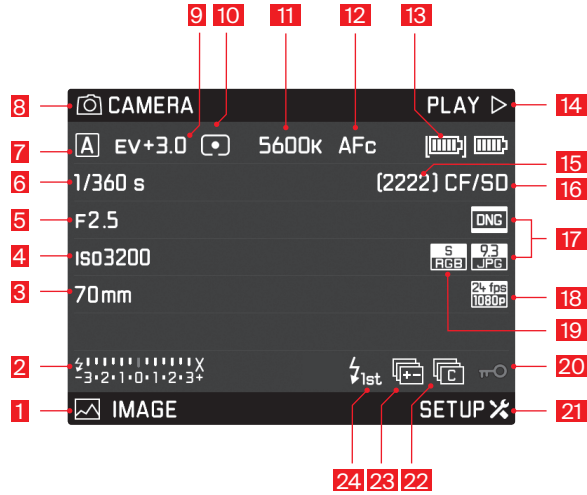

- 1 Function of the button bottom left
- 2 Flash ready indicator, light balance, flash sync speed indicator
- 3 Focal length
- 4 ISO sensitivity/setting
- 5 Aperture
- 6 Shutter speed
- 7 Exposure operating mode
- 8 Function of the button top left
- 9 Exposure compensation
- 10 Exposure metering method
- 11 White balance setting
- 12 Autofocus mode
- 13 Battery status / mains mode
- 14 Function of the button top right
- 15 Picture counter
- 16 Memory card(s) used
- 17 Photo file format / JPG resolution
- 18 Video resolution / frame rate
- 19 Color space
- 20 Button lock activated
- 21 Function of the button bottom right
 - Single picture
 - Picture series
 - Interval shooting
 - Self-timer mode
- 23 Exposure bracketing activated
- 24 Flash trigger point

Capturing mode Live View photo

Standard view

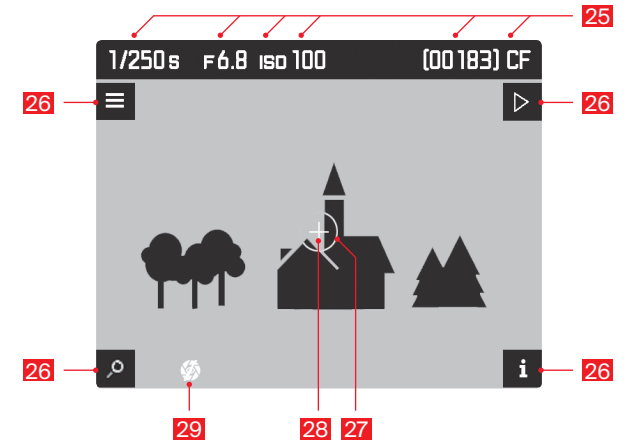

25 see 6, 5, 4, 15, 16

26 Button functions

(appear – in all Live View screens – for approx. 3 s after pressing any of the four buttons next to the monitor)

- Magnification function
- Menu control
- Review mode
- Change views

27 Spot exposure metering field

28 Autofocus metering field

29 Exposure simulation deactivated

Standard view plus additional displays

A. Histogram and clipping indicators

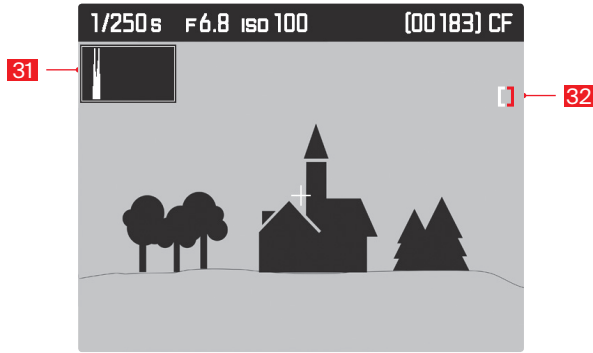

- 31 Histogram
- 32 Clipping symbol

B. Focus display (peaking)

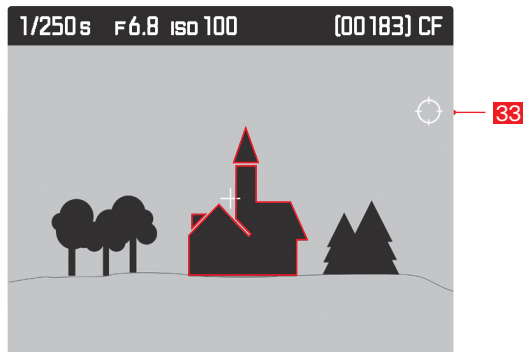

- 33 Peaking symbol

C. Grid and horizon

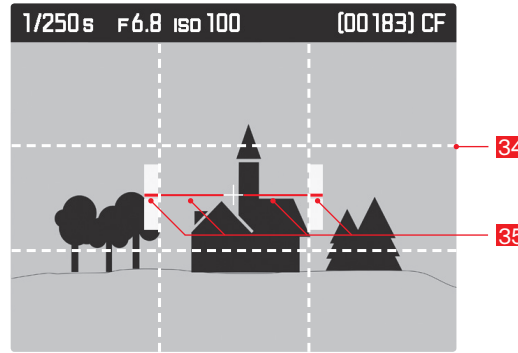

- 34 Grid lines
- 35 Horizon

D. Additional picture data

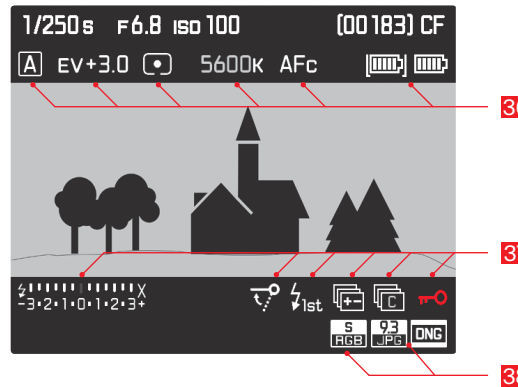

- 36 see 7, 9, 10, 11, 12, 13
- 37 see 2, 25, 24, 23, 22, 20
- 38 see 19, 17

Video recording mode

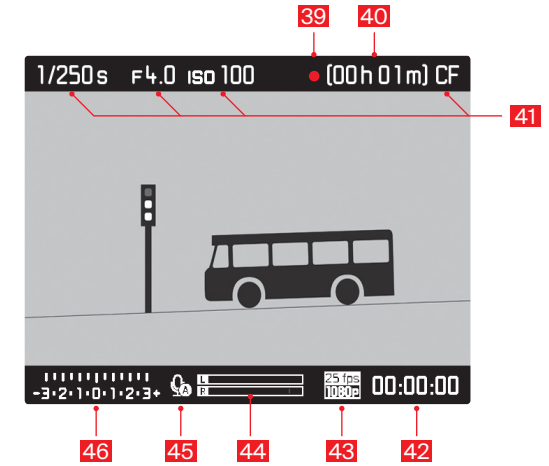

- 39 Indication of a recording in progress
- 40 Possible recording time
- 41 see 6, 5, 4, 16
- 42 Current recording time
- 43 Video resolution / frame rate
- 44 Audio recording level display
- 45 Sound recording mode
 - Automatic recording level control
 - Manual recording level control
 - Sound recording deactivated
- 46 Light scale, or headphone volume, Volume off (mute)

Photo review mode

Standard view

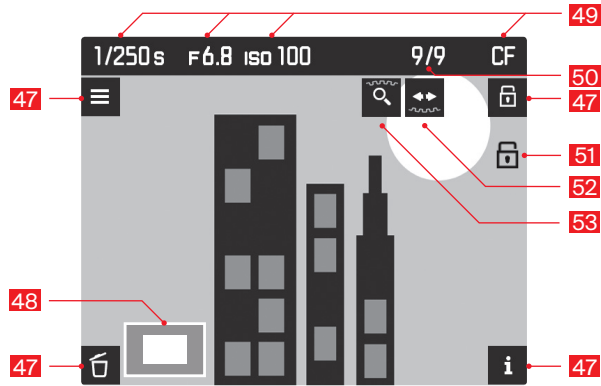

47 Button functions

(appear when switching on Review mode in all photo and video views or after pressing any of the four buttons next to the monitor, disappear after approx. 3 s)

- Delete menu
- Menu control
- Protect menu
- Change views

48 Detail size and position

49 see 6, 5, 4, 16

50 Number of picture displayed / total number of pictures

51 Symbol for delete-protected pictures

52 Operating instructions for scroll function (shutter speed setting dial)

53 (52 and 53 appear / disappear together with 47)

Operating instructions for enlargement function (thumbwheel)

Standard view plus additional displays

A. Histogram and clipping indicator

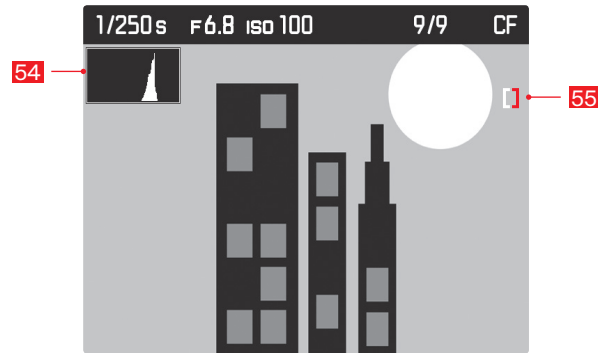

54 Histogram

55 Clipping symbol

B. Focus display (peaking)

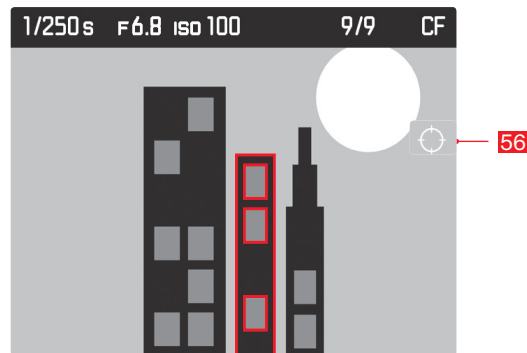

56 Peaking symbol

C. Additional picture data

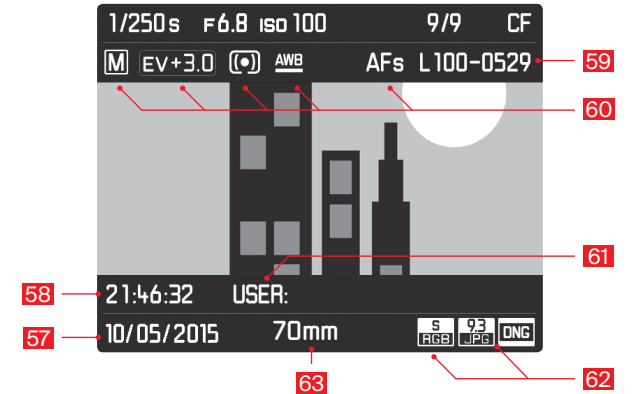

57 Date of picture

58 Time of picture

59 Image file number

60 see 7, 9, 10, 11, 12

61 Profile memory slot

62 see 19, 17

63 Employed focal length

Video review mode



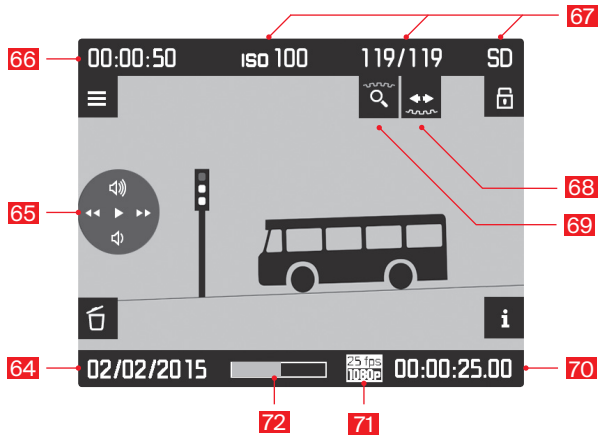

Standard view



64 Recording date and volume setting 

Volume off (mute) , see also **65**

65 Video control symbols (for Joystick)

-  Playback (press forward)
-  Fast forward (press to right or hold depressed)
-  Fast rewind (press to left or hold depressed)
-  Volume: louder (press up or hold depressed)
-  Volume: quieter (press down or hold depressed)

66 Total recording time

67 see **4**, **50**, **16**

68 Operating instructions for scroll function (shutter speed setting dial)

69 Operating instructions for enlargement function (thumbwheel)

70 Elapsed playback time

71 Video resolution / frame rate

72 Elapsed playback time bar

Standard view plus additional displays

A. Histogram and clipping indicator

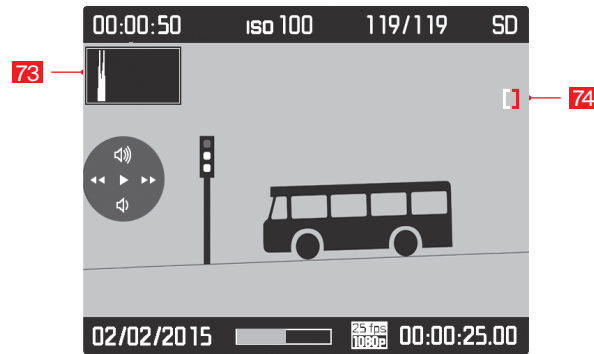

73 Histogram

74 Clipping symbol

B. Focus display (peaking)

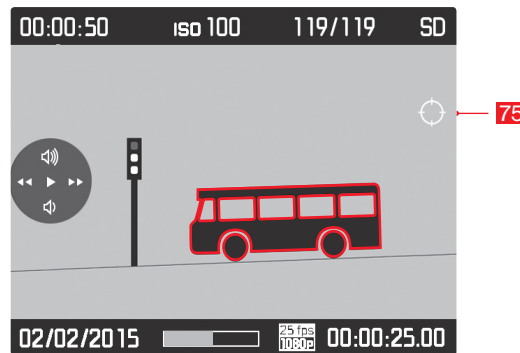

75 Peaking symbol

C. Additional picture data

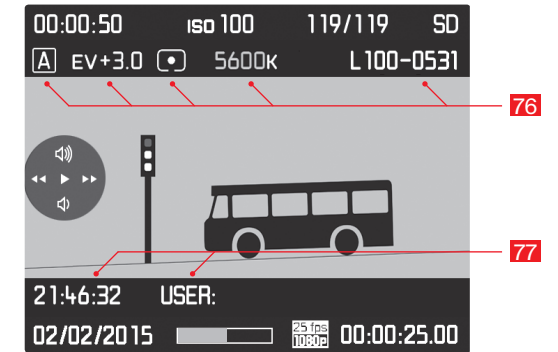

76 see **7**, **9**, **10**, **11**, **59**

77 see **58**, **61**

THE MENU OPTIONS

Area	Menu option	Page
CAMERA	Drive mode	26/34
	Focus mode	29
	Exp. metering	30
	Exp. compensation	32
	Exp. bracketing	33

Area	Menu option	Page
IMAGE	ISO	24
	White balance	22
	Photo file format	22
	JPG resolution	22
	JPG settings	22
	Video resolution	43
	Video setting	43/45

Area	Menu option	Page
SETUP	Storage backup (CF & SD)	25
	Format cards	37
	Image numbering	37
	Auto review	46
	Capture assistants	27/28/29/47
	Copyright information	38
	User profiles	36
	Auto ISO setup	24
	Flash sync. mode	40
	Keylock	30
	Customize controls	32
	Display brightness	21
	Acoustic signals	21
	Auto power saving	20
	WLAN	52
	Date & time	20
Language	20	
Reset camera	36	
Camera information	2/51	

Sinar Service Addresses

Sinar product support

The Product Support Department at Sinar Photography AG can provide you with an answer to any technical questions relating to Sinar products, including software supplied, either in writing, on the telephone, or by e-mail. They are also the contact point for purchasing advice and to order instruction manuals. Alternatively, you can send us your questions using the contact form on the Sinar Photography AG homepage.

Sinar Photography AG
Product Support / Software Support
Farbhofstrasse 21
CH-8048 Zürich / Switzerland
Phone: +41 44 217 80 30
Fax: +41 44 217 80 50
tech@sinar.swiss / contact@sinar.swiss

Sinar customer care

For servicing your Sinar equipment or in the event of damage, the Sinar Photography AG Customer Care department or the repair service provided by authorized Sinar agents in your country are available (visit www.sinar.swiss/resellers for a list of addresses).

Sinar Photography AG
Product Support / Software Support
Farbhofstrasse 21
CH-8048 Zürich / Switzerland
Phone: +41 44 217 80 30
Fax: +41 44 217 80 50
tech@sinar.swiss / contact@sinar.swiss

Sinar Photography AG
Farbhofstrasse 21
8048 Zürich, Switzerland
Phone +41 44 217 8030
contact@sinar.swiss
www.sinar.swiss

© Sinar Photography AG, Switzerland, 06/17
SIN-000.002-103
Technical modifications reserved